

P-10152

S2587

35562

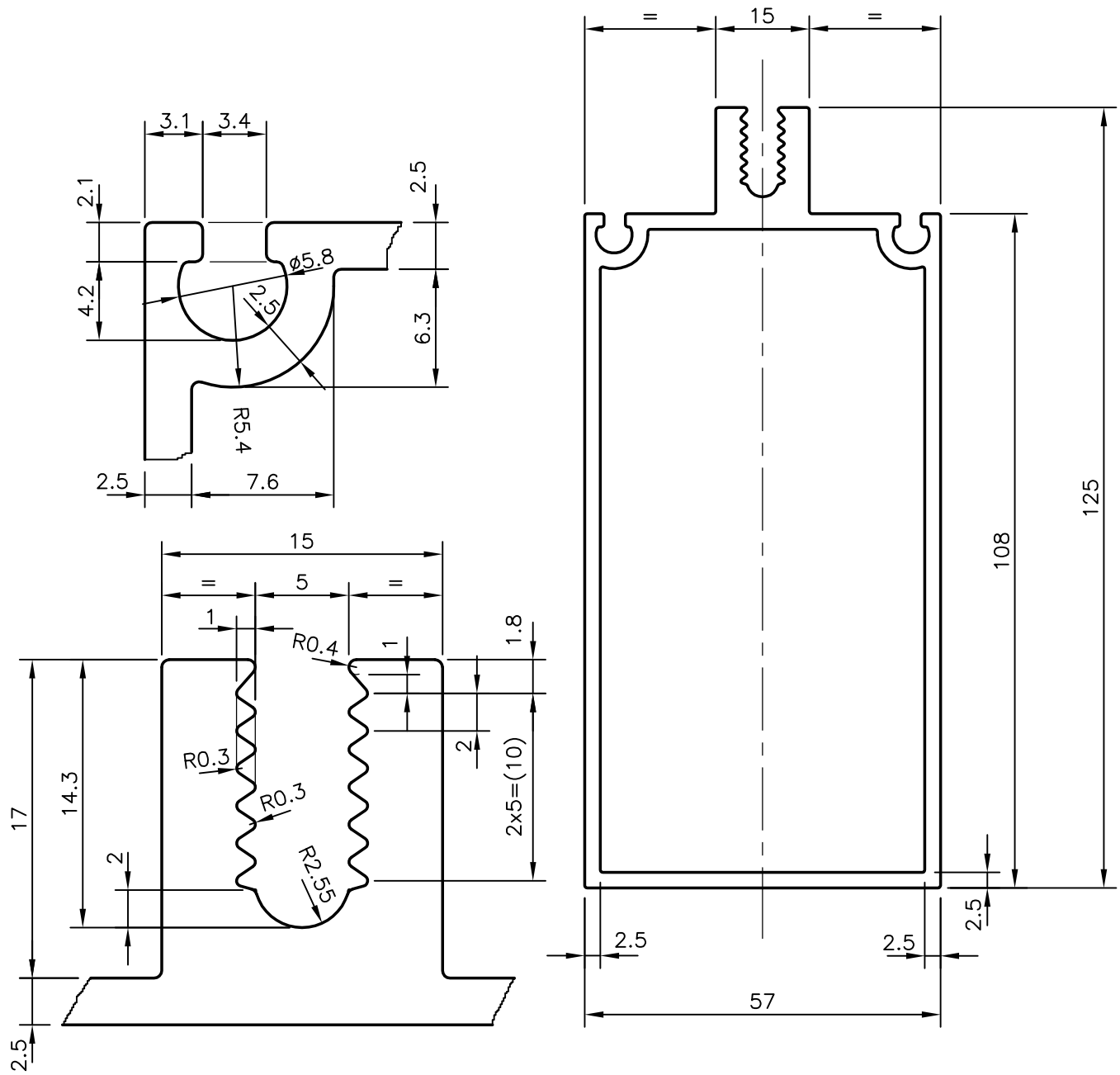

SYMBOL OF QUALITY
AN ISO 9001 COMPANY

JINDAL ALUMINIUM LTD.
BANGALORE-560073 (INDIA)

| | NAME | DATE |
|----------------------|-------------|------------|
| DRAWN | J.P.KAUSHIK | 03-07-2010 |
| CHECKED | | |
| APPROVED | S.S.GARG | 14-07-2010 |
| SCALE | | 1:1 |
| AREA mm ² | | 1001.147 |
| PERIMETER mm. | | 427.542 |
| WEIGHT kg/m | | 2.703 |

1. ALL DIMENSIONS ARE IN mm.
2. ROUND OFF ALL SHARP CORNERS WITH 0.40 mm.
3. TOLERANCES WILL BE AS PER BS:EN-12020-2 UNLESS OTHERWISE SPECIFIED

| | |
|---------------------|---------------------------------------|
| PARTY'S NAME | FG GLASS INDUSTRIES PVT. LTD., MUMBAI |
| PARTY'S DRAWING No. | D-01 |
| ALLOY & TEMPER | HE9 WP |
| DESCRIPTION | CURTAIN WALL SECTION |

| DRAWING No. | SECTION No. |
|-------------|-------------|
| P-10152 | - |
| S2587 | S2587 |
| 35562 | 35562 |