

P-9500-2

S2297

35564

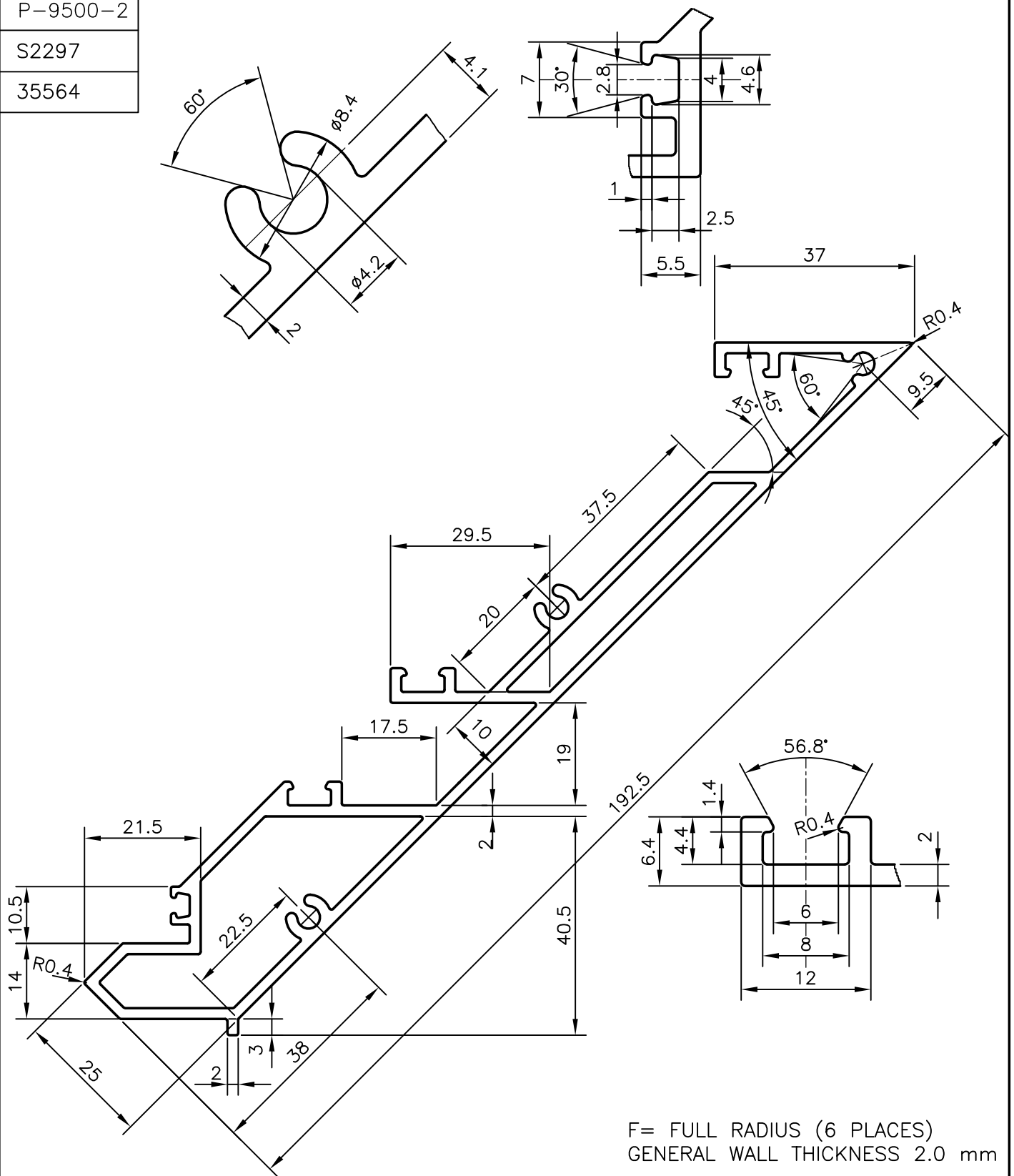

F= FULL RADIUS (6 PLACES)  
GENERAL WALL THICKNESS 2.0 mm



SYMBOL OF QUALITY  
AN ISO 9001 COMPANY

**JINDAL ALUMINIUM LTD.**  
BANGALORE-560073 (INDIA)

	NAME	DATE
DRAWN	J.P.KAUSHIK	06-10-2009
CHECKED		
APPROVED		
SCALE		1:1
AREA mm <sup>2</sup>		970.679
PERIMETER mm.		629.176
WEIGHT kg/m		2.621
DRAWING No.	SECTION No.	
P-9500-2	-	
S2297	S2297	
35564	35564	

- ALL DIMENSIONS ARE IN mm.
- ROUND OFF ALL SHARP CORNERS WITH 0.40 mm.
- TOLERANCES WILL BE AS PER IS:6477-1983 UNLESS OTHERWISE SPECIFIED

PARTY'S NAME	SP FABRICATORS PVT. LTD., NAVI MUMBAI
PARTY'S DRAWING No.	AL-613
ALLOY & TEMPER	6063 T6
DESCRIPTION	CORNER MULLION SECTION