

P-10217-1

S2630

35573

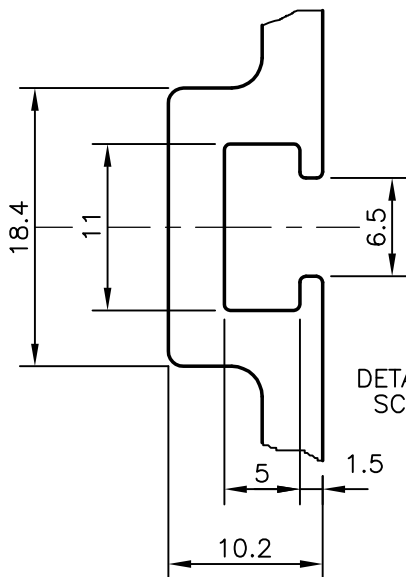
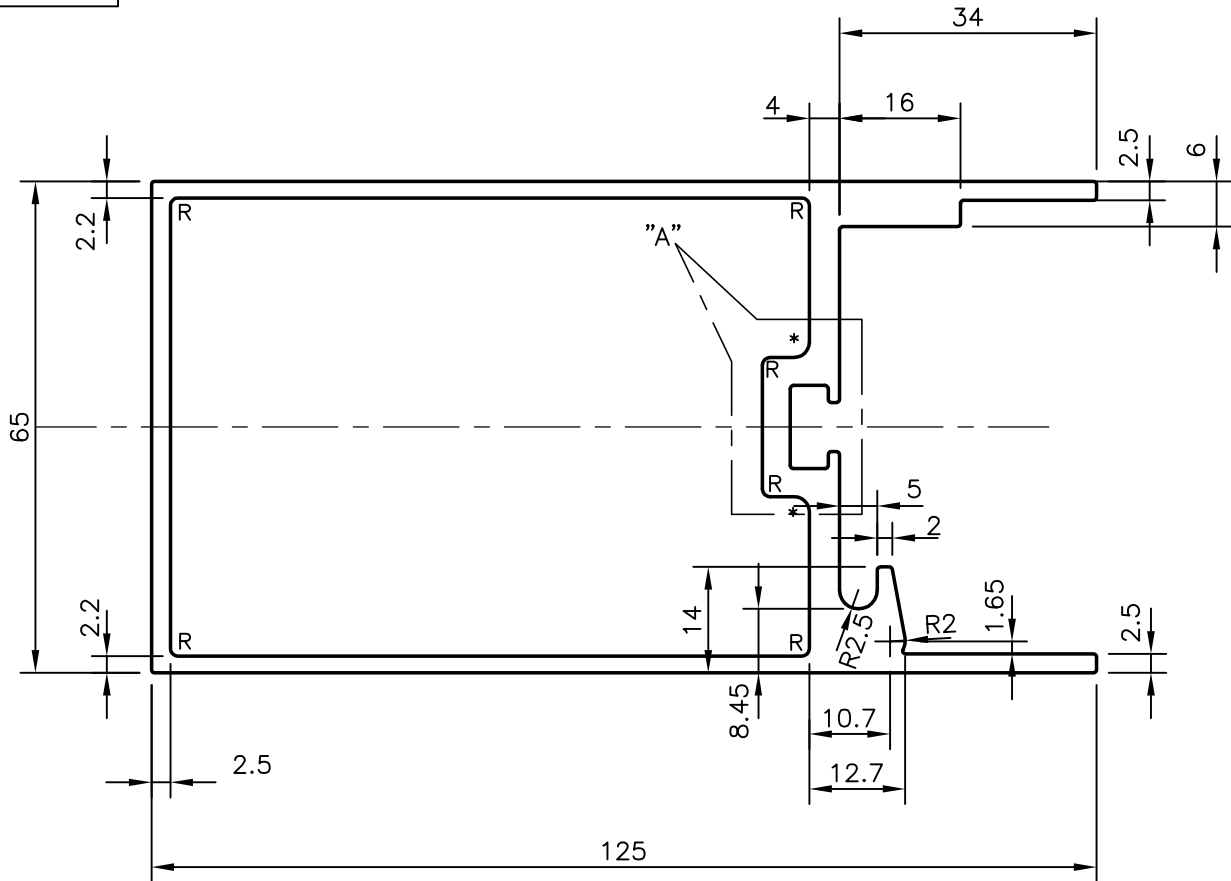

DETAIL OF "A"
SCALE 2:1

* = 2.0 RADIUS (2)
R = 1.0 RADIUS (6)



SYMBOL OF QUALITY
AN ISO 9001 COMPANY

JINDAL ALUMINIUM LTD.
BANGALORE-560073 (INDIA)

	NAME	DATE
DRAWN	J.P.KAUSHIK	28-07-2010
CHECKED		
APPROVED	S.S.GARG	05-08-2010

1. ALL DIMENSIONS ARE IN mm.
2. ROUND OFF ALL SHARP CORNERS WITH 0.40 mm.
3. TOLERANCES WILL BE AS PER BS:EN-12020-2 UNLESS OTHERWISE SPECIFIED

SCALE	1:1
AREA mm ²	1137.716
PERIMETER mm.	474.39
WEIGHT kg/m	3.072

PARTY'S NAME	AHLCONS INDIA PVT. LTD., NEW DELHI
PARTY'S DRAWING No.	BH-6839
ALLOY & TEMPER	HE9 WP
DESCRIPTION	CURTAIN WALL SECTION (TRANSOM)

DRAWING No.	SECTION No.
P-10217-1	-
S2630	S2630
35573	35573