

P-10218

S2631

35574

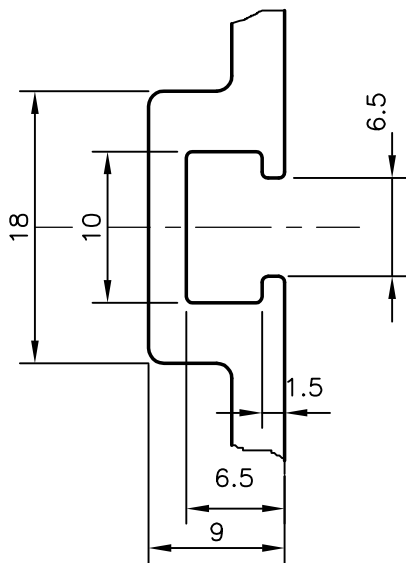
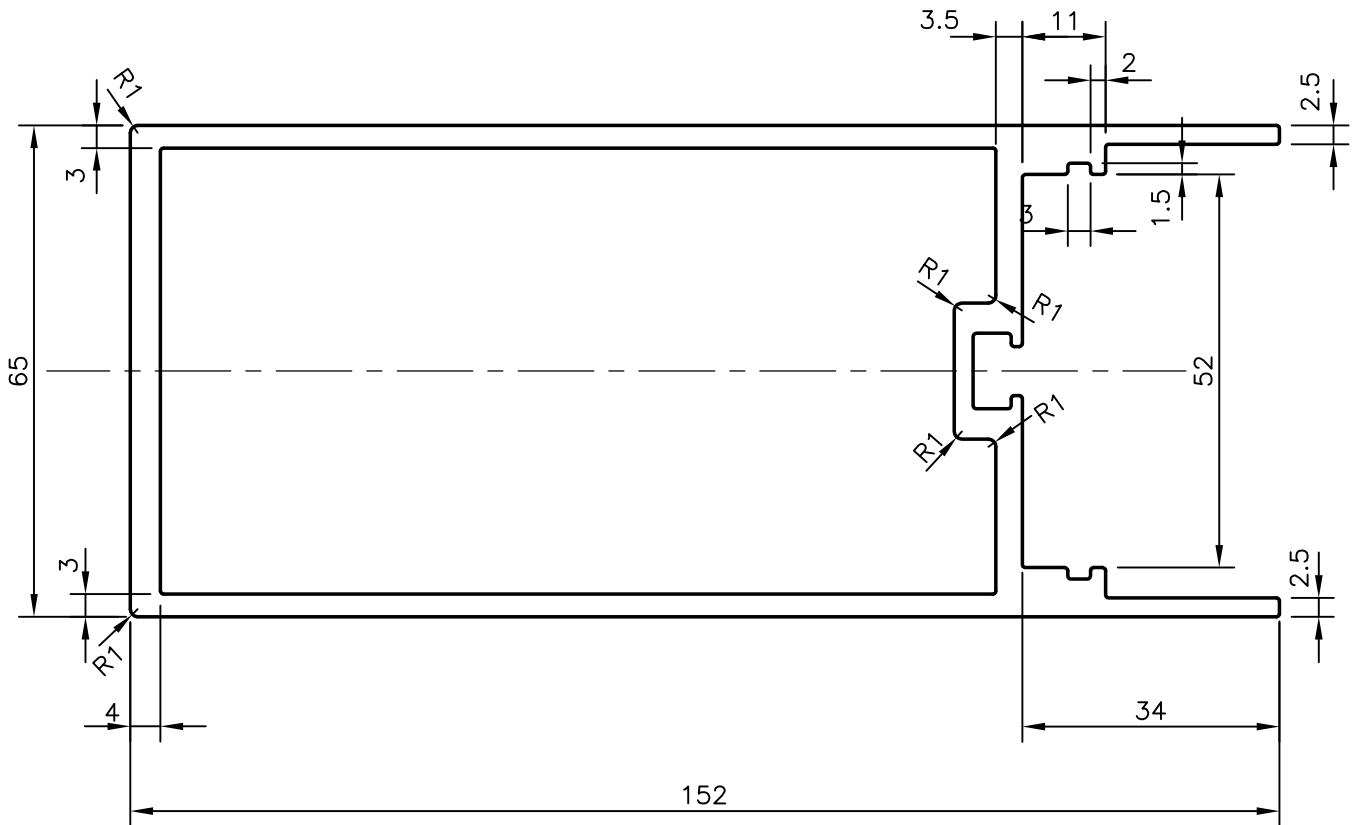

SYMBOL OF QUALITY  
AN ISO 9001 COMPANY

**JINDAL ALUMINIUM LTD.**  
BANGALORE-560073 (INDIA)

	NAME	DATE
DRAWN	J.P.KAUSHIK	24-07-2010
CHECKED		
APPROVED	S.S.GARG	05-08-2010
SCALE		1:1
AREA mm <sup>2</sup>		1438.524
PERIMETER mm.		522.678
WEIGHT kg/m		3.884
DRAWING No.	SECTION No.	
P-10218	-	
S2631	S2631	
35574	35574	

1. ALL DIMENSIONS ARE IN mm.
2. ROUND OFF ALL SHARP CORNERS WITH 0.40 mm.
3. TOLERANCES WILL BE AS PER BS:EN-12020-2 UNLESS OTHERWISE SPECIFIED

PARTY'S NAME	AHLCONS INDIA PVT. LTD., NEW DELHI
PARTY'S DRAWING No.	BH-5456
ALLOY & TEMPER	6063 T6
DESCRIPTION	CURTAIN WALL SECTION (MULLION)