

P-9710-2

S2473

35588

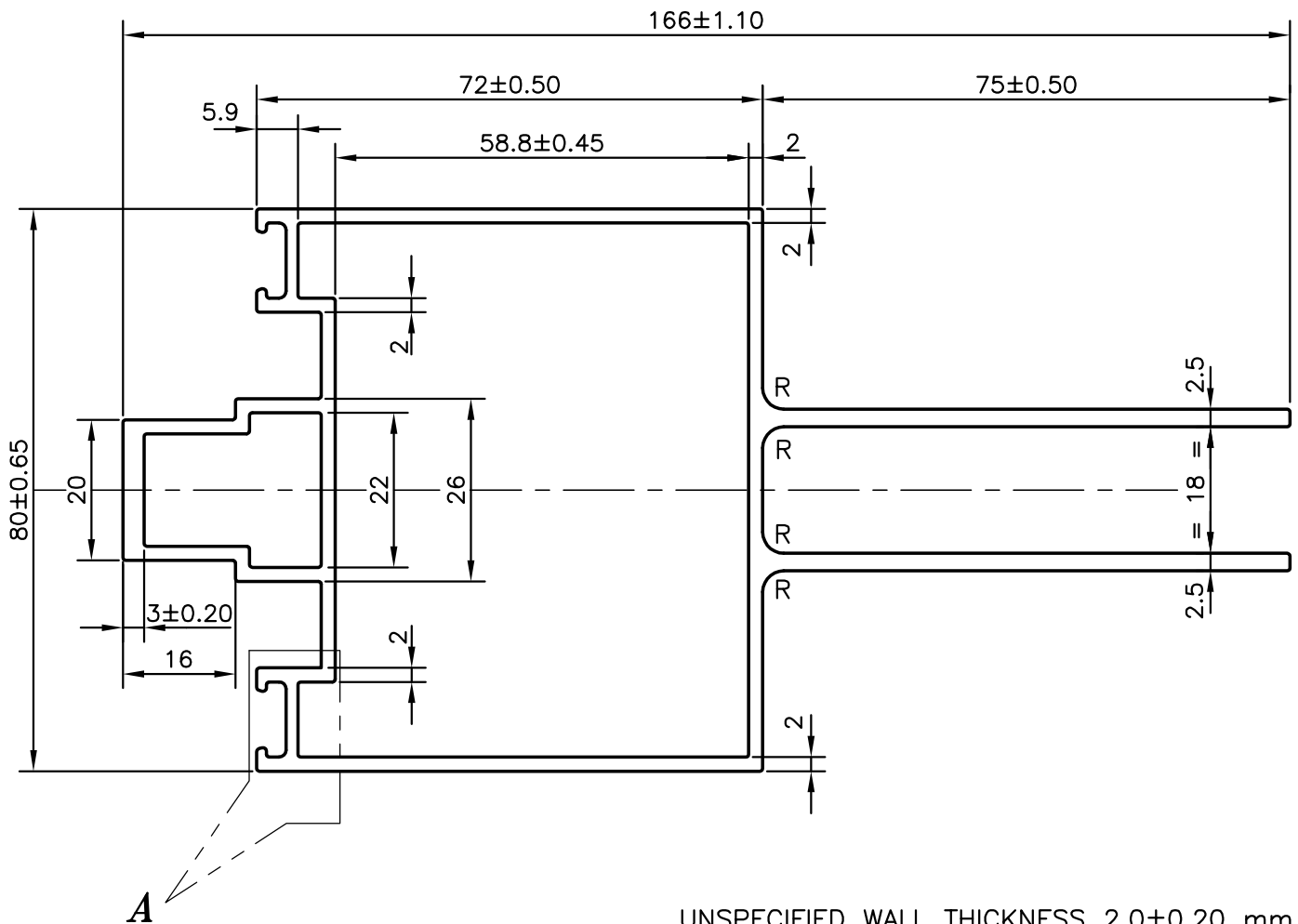
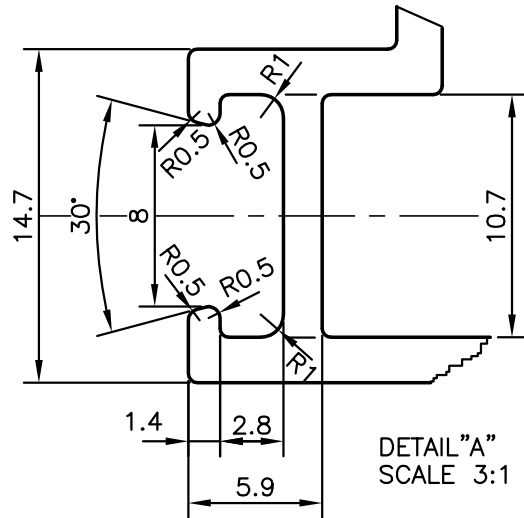
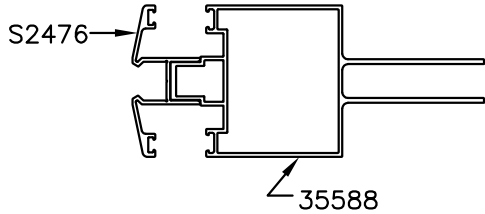

UNSPECIFIED WALL THICKNESS 2.0±0.20 mm
R = 3.0 RADIUS (4 PLACES)



SYMBOL OF QUALITY
AN ISO 9001 COMPANY

JINDAL ALUMINIUM LTD.
BANGALORE-560073 (INDIA)

	NAME	DATE
DRAWN	J.P.KAUSHIK	08-02-2010
CHECKED		
APPROVED	S.S.GARG	03-03-2010
SCALE		1:1
AREA mm ²		1185.726
PERIMETER mm.		693.495
WEIGHT kg/m		3.201
DRAWING No.	SECTION No.	
P-9710-2	-	
S2473	S2473	
35588	35588	

1. ALL DIMENSIONS ARE IN mm.
2. ROUND OFF ALL SHARP CORNERS WITH 0.40 mm.
3. TOLERANCES WILL BE AS PER IS:6477-1983, UNLESS OTHERWISE SPECIFIED

PARTY'S NAME	SP FABRICATORS PVT. LTD., MUMBAI
PARTY'S DRAWING No.	AL- 638
ALLOY & TEMPER	6063 T6
DESCRIPTION	MULLION PROFILE SECTION