

P-9326
S2241
35604

DETAIL OF 'B'
SCALE 3:1

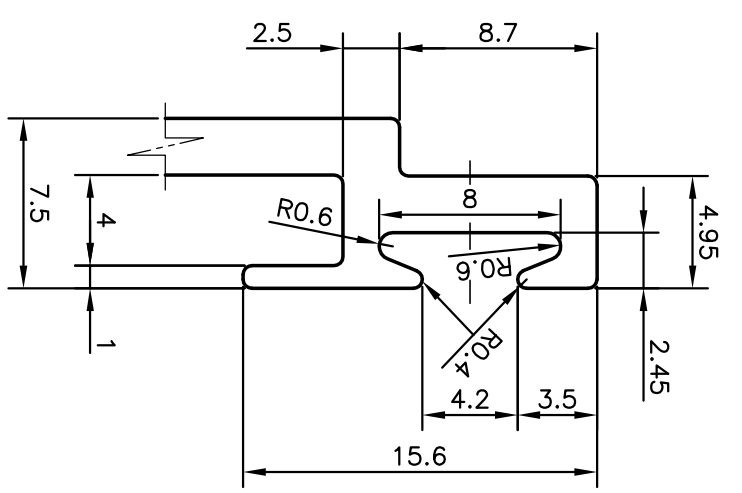

DETAIL OF 'A'
SCALE 3:1

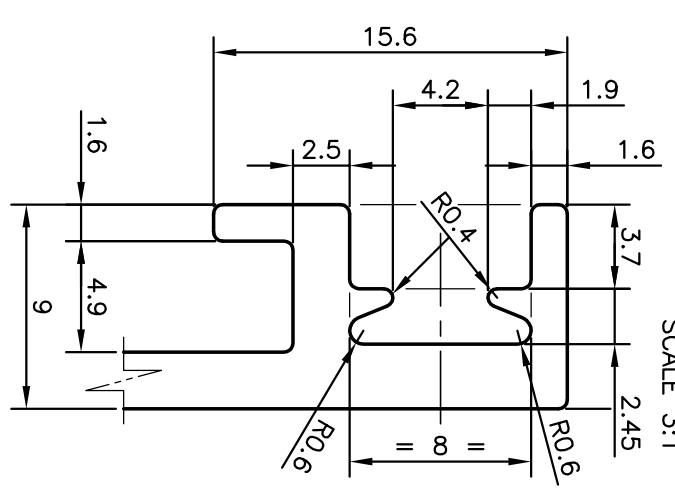

DETAIL OF 'D'
SCALE 3:1

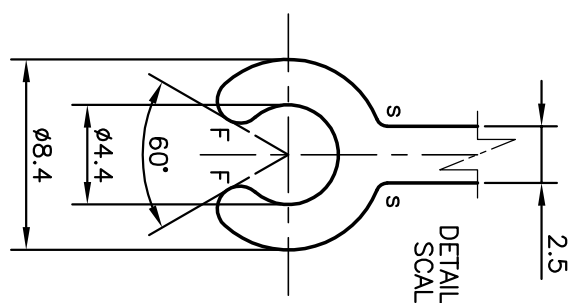

DETAIL OF 'C'
SCALE 3:1

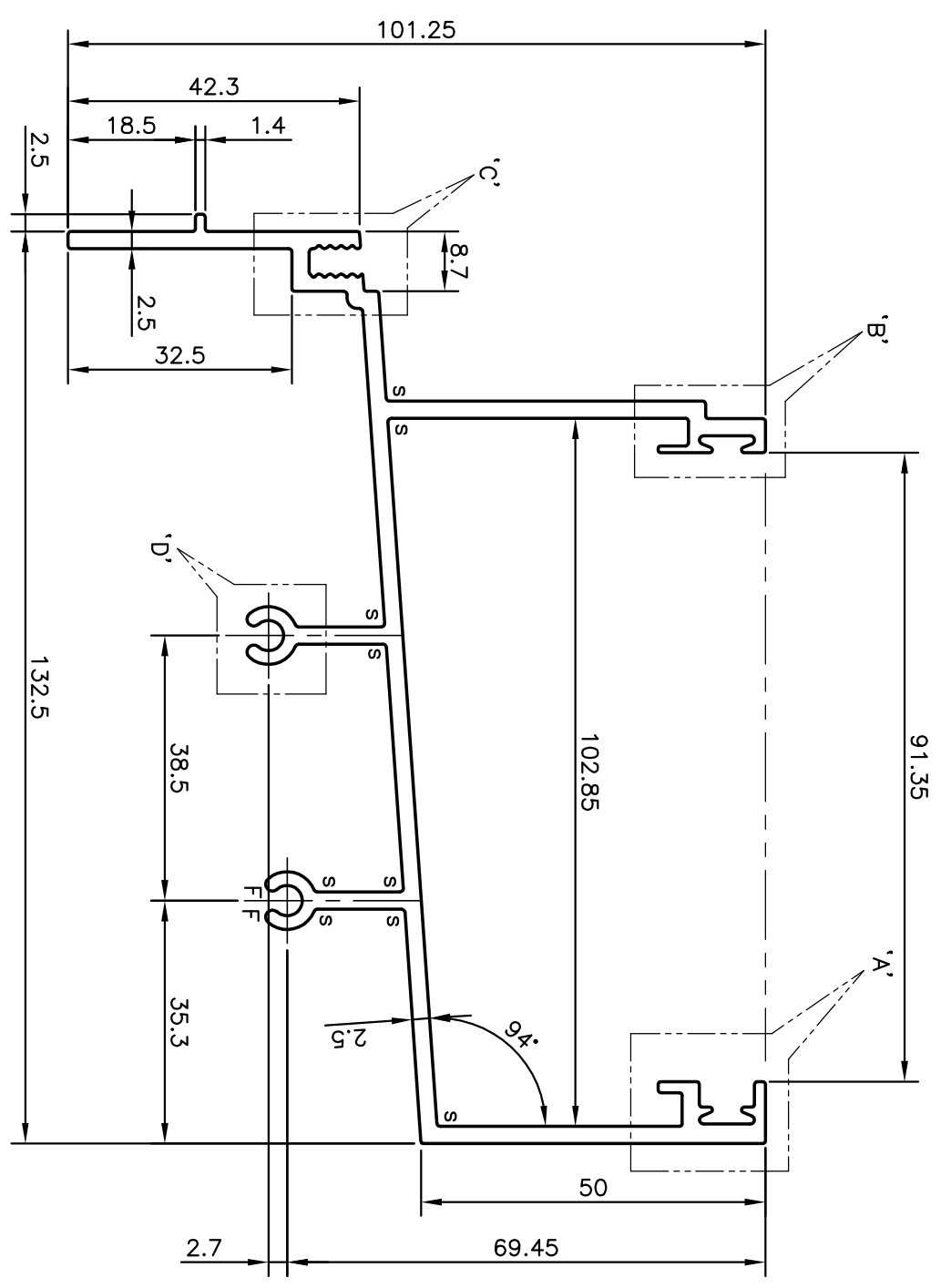
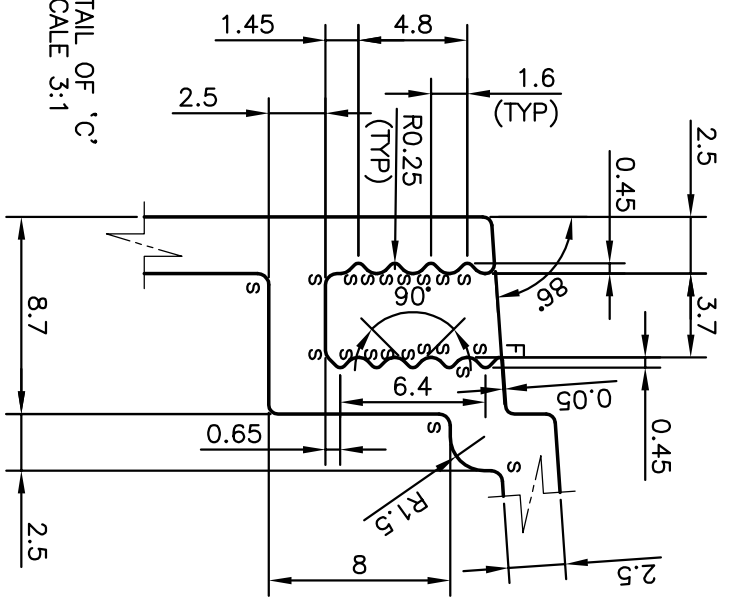

F = FULL RADIUS (4)
S = R0.5 mm (31 PLACES)

1. ALL DIMENSIONS ARE IN mm.
2. ROUND OFF ALL SHARP CORNERS WITH 0.40 mm.
3. TOLERANCES WILL BE AS PER IS:3965-1981 UNLESS OTHERWISE SPECIFIED

 JINDAL ALUMINIUM LTD. BANGALORE-560073 (INDIA)		NAME	DATE
		DRAWN	PRASANNA.H 25-06-2009
1. ALL DIMENSIONS ARE IN mm. 2. ROUND OFF ALL SHARP CORNERS WITH 0.40 mm. 3. TOLERANCES WILL BE AS PER IS:3965-1981 UNLESS OTHERWISE SPECIFIED		CHECKED	
PARTY'S NAME		APPROVED	
PARTY'S DRAWING No.		SCALE	1:1
ALLOY & TEMPER		AREA mm ²	905.153
DESCRIPTION		PERIMETER mm.	754.527
GUTTER SECTION		WEIGHT kg/m	2.444
		DRAWING No.	SECTION No.
		P-9326	-
		S2241	S2241
		35604	35604