

P-6537

S1813

X609

35618

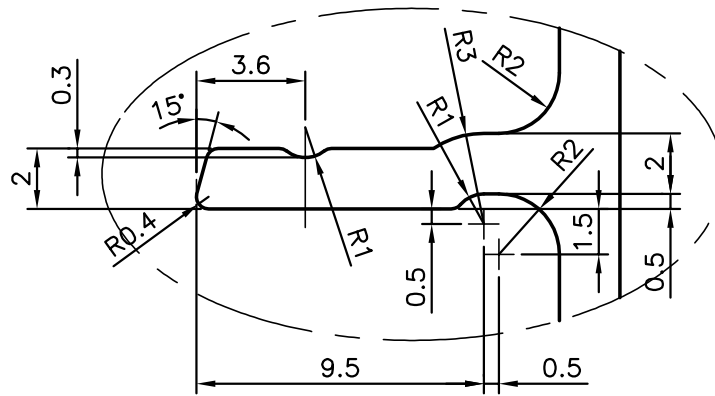

**DETAIL-A**  
SCALE: -4:1

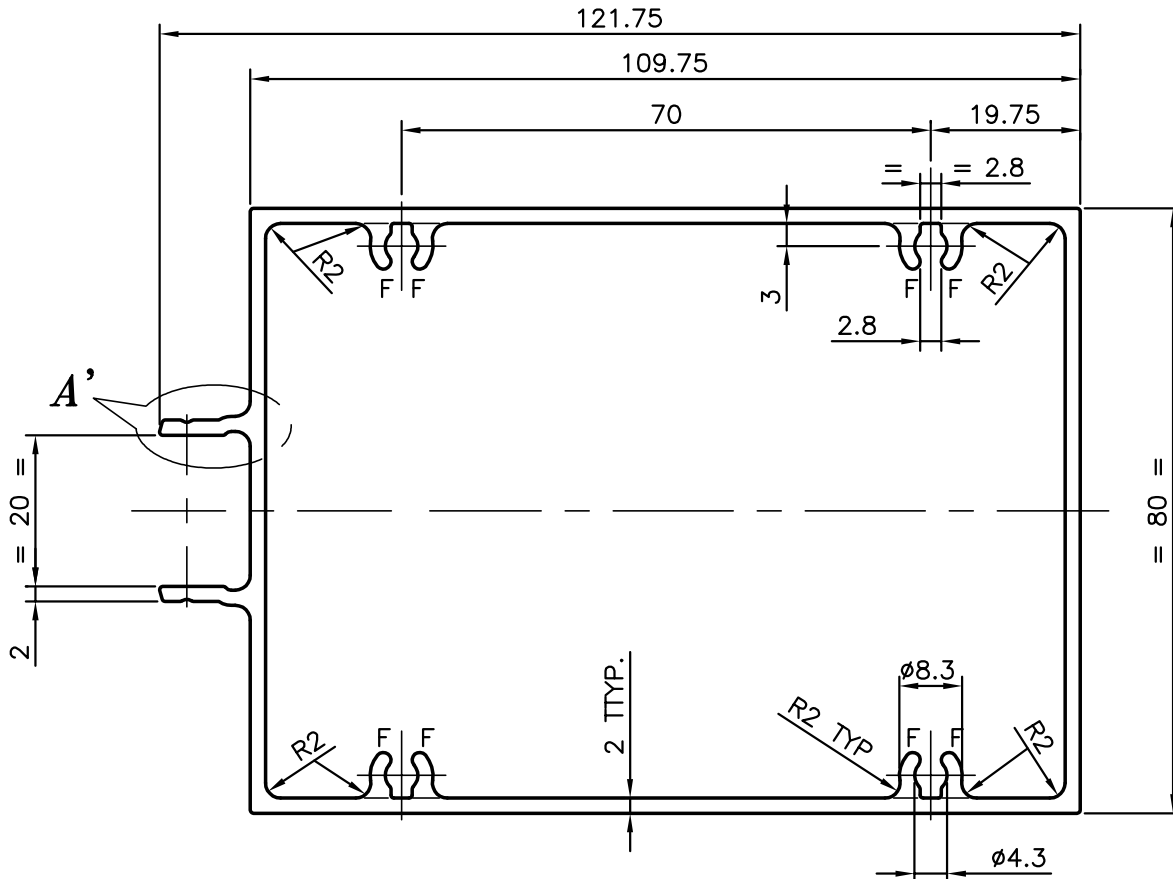

UNSPECIFIED WALL THICKNESS = 2 mm  
F = FULL RADIUS (8 PLACES)



SYMBOL OF QUALITY  
AN ISO 9001 COMPANY

**JINDAL ALUMINIUM LTD.**  
BANGALORE-560073 (INDIA)

	NAME	DATE
DRAWN	malingappa	01-07-2006
CHECKED		
APPROVED		

1. ALL DIMENSIONS ARE IN mm.
2. ROUND OFF ALL SHARP CORNERS WITH 0.40 mm.
3. TOLERANCES WILL BE AS PER IS:6477-1983 UNLESS OTHERWISE SPECIFIED

SCALE	1:1
AREA mm <sup>2</sup>	909.676
PERIMETER mm.	422.901
WEIGHT kg/m	2.456

PARTY'S NAME	ALUPLEX INDIA PVT. LTD., MUMBAI
PARTY'S DRAWING No.	AS PER DRAWING
ALLOY & TEMPER	HE9 WP
DESCRIPTION	CURTAIN WALL SECTION

DRAWING No.	SECTION No.
P-6537	-
S1813	S1813
X609	X609
35618	35618