

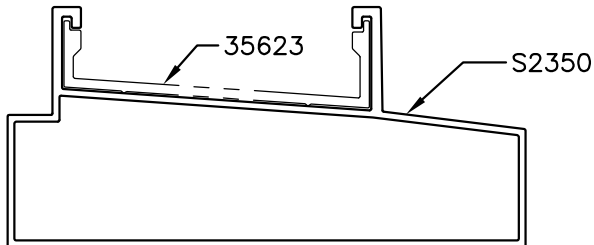

P-9553
S2343
35623

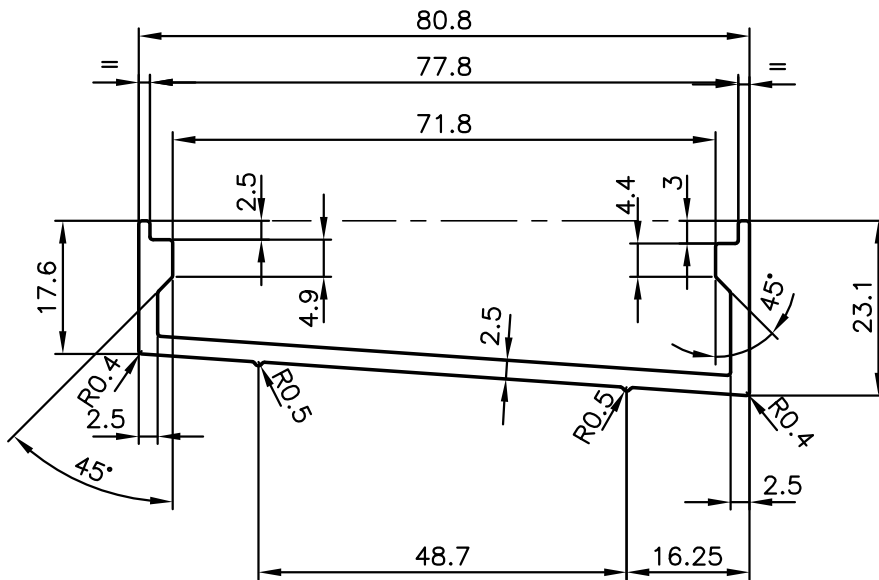

 SYMBOL OF QUALITY AN ISO 9001 COMPANY	<b>JINDAL ALUMINIUM LTD.</b> BANGALORE-560073 (INDIA)	NAME J.P.KAUSHIK	DATE 24-10-2009
		DRAWN	CHECKED
1. ALL DIMENSIONS ARE IN mm. 2. ROUND OFF ALL SHARP CORNERS WITH 0.40 mm. 3. TOLERANCES WILL BE AS PER IS:3965-1981 UNLESS OTHERWISE SPECIFIED		SCALE 1:1	AREA mm <sup>2</sup> 309.51
PARTY'S NAME SP FABRICATORS PVT. LTD., NAVI MUMBAI		PERIMETER mm. 242.712	WEIGHT kg/m 0.836
PARTY'S DRAWING No. AL-628		DRAWING No. P-9553	SECTION No. -
ALLOY & TEMPER 6063 T6		S2343	S2343
DESCRIPTION SPLICE PLATE		35623	35623