

P-9546-2
S2358
35628

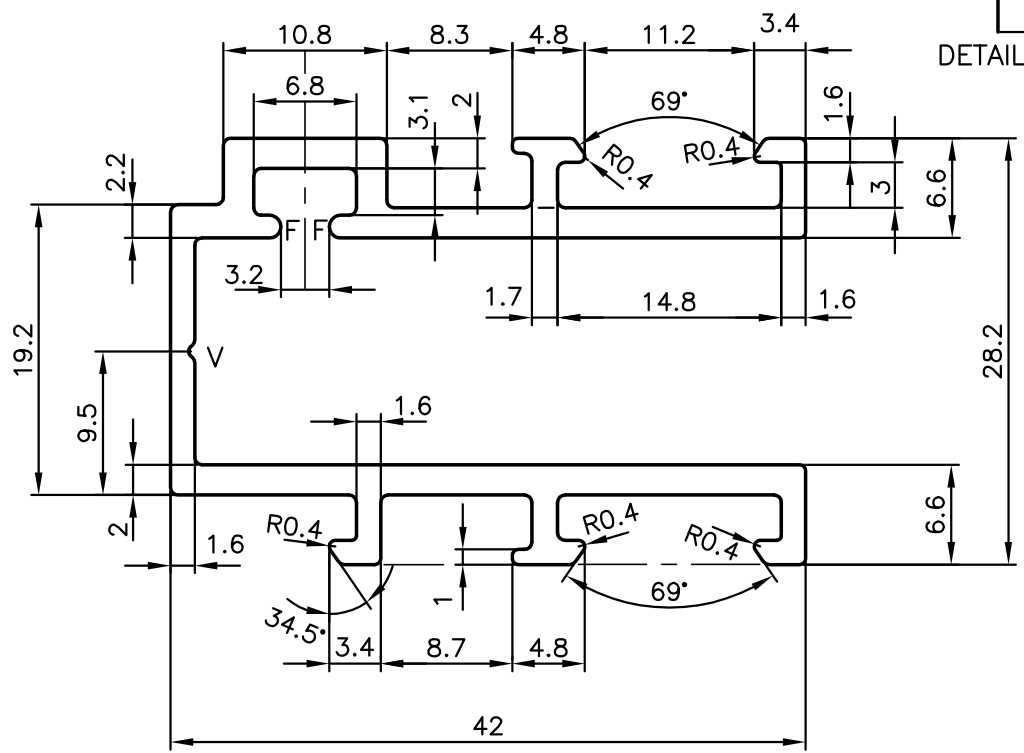

F = FULL RADIUS (2 PLACES)
UNSPECIFIED RADII 0.5 mm

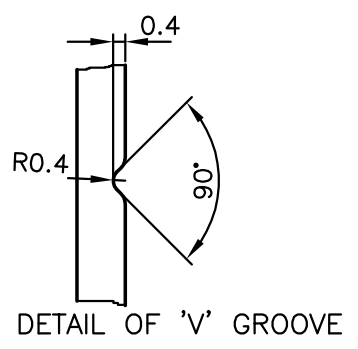
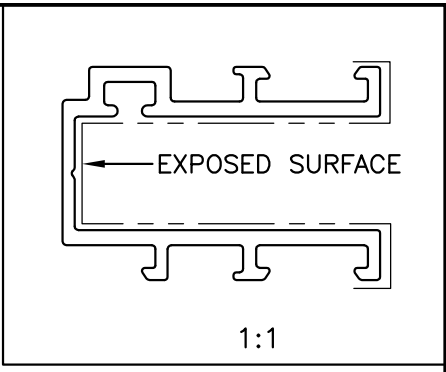
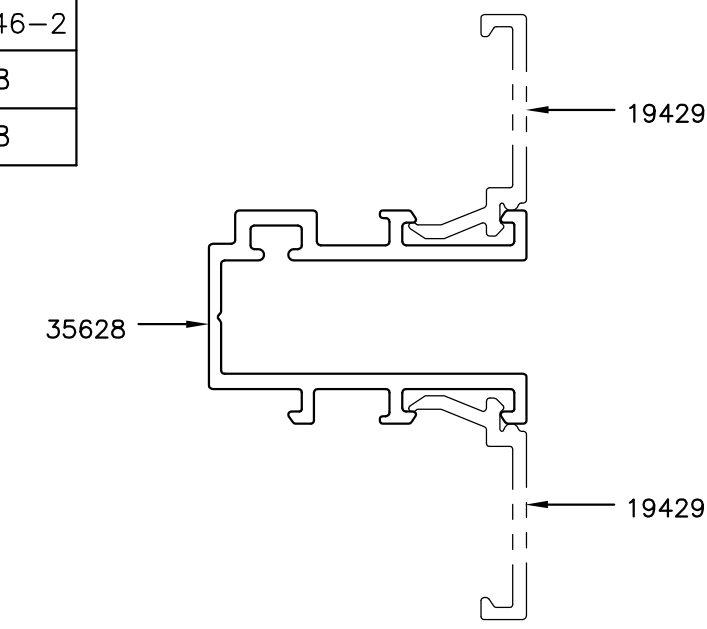

JINDAL ALUMINIUM LTD.
BANGALORE-560073 (INDIA)

	NAME	DATE
DRAWN	J.P.KAUSHIK	07-11-2009
CHECKED		
APPROVED		

- ALL DIMENSIONS ARE IN mm.
- ROUND OFF ALL SHARP CORNERS WITH 0.50 mm.
- TOLERANCES WILL BE AS PER IS:3965-1981, UNLESS OTHERWISE SPECIFIED

SCALE	2:1
AREA mm ²	268.828
PERIMETER mm.	285.83
WEIGHT kg/m	0.726

PARTY'S NAME	SP FABRICATORS PVT. LTD., NAVI MUMBAI
PARTY'S DRAWING No.	AL-621
ALLOY & TEMPER	6063 T6
DESCRIPTION	ADAPTER

DRAWING No.	SECTION No.
P-9546-2	-
S2358	S2358
35628	35628