

P-9618

S2364

35629

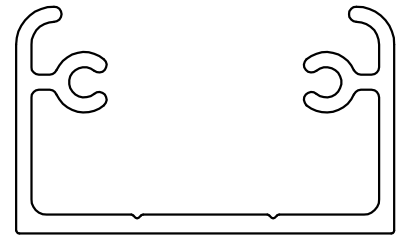

1:1

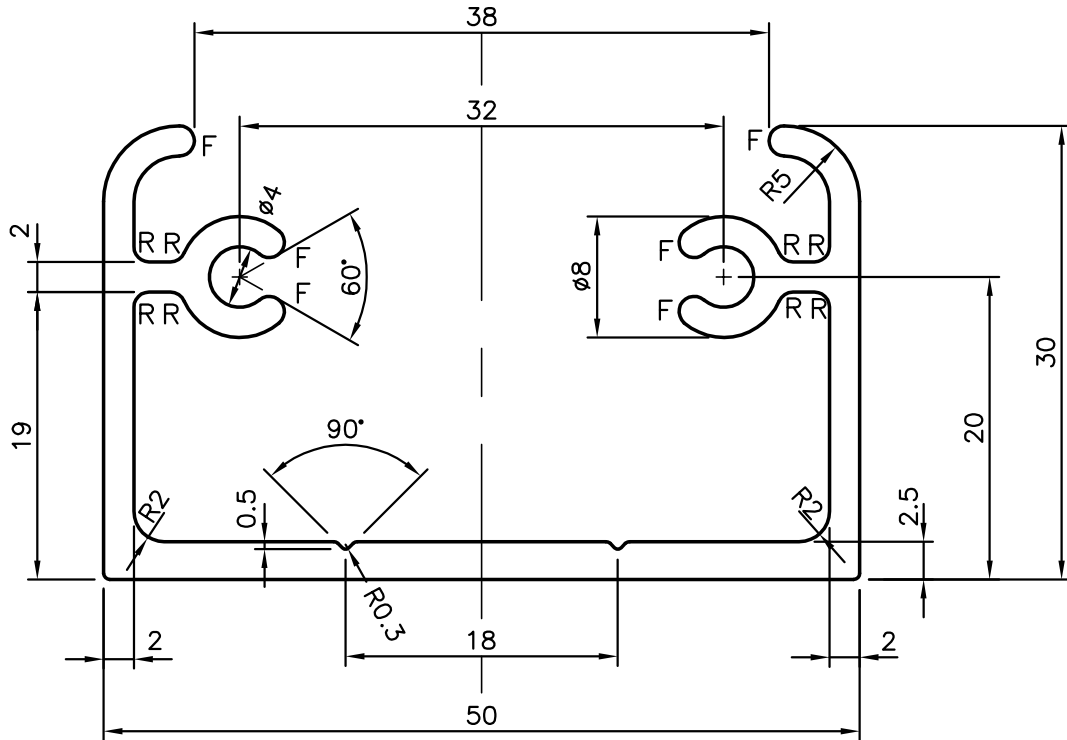

F = FULL RADIUS(6 PLACES)  
R = 1.0 RADIUS(8 PLACES)



SYMBOL OF QUALITY  
AN ISO 9001 COMPANY

**JINDAL ALUMINIUM LTD.**  
BANGALORE-560073 (INDIA)

	NAME	DATE
DRAWN	J.P.KAUSHIK	06-11-2009
CHECKED		
APPROVED		

1. ALL DIMENSIONS ARE IN mm.
2. ROUND OFF ALL SHARP CORNERS WITH 0.40 mm.
3. TOLERANCES WILL BE AS PER IS:3965-1981, UNLESS OTHERWISE SPECIFIED

SCALE	2:1
AREA mm <sup>2</sup>	318.498
PERIMETER mm.	290.312
WEIGHT kg/m	0.860

PARTY'S NAME	S S FACADE PVT. LTD., GURGAON
PARTY'S DRAWING No.	4710
ALLOY & TEMPER	6063 T6
DESCRIPTION	TRANSOM CONNECTOR SECTION

DRAWING No.	SECTION No.
P-9618	-
S2364	S2364
35629	35629