

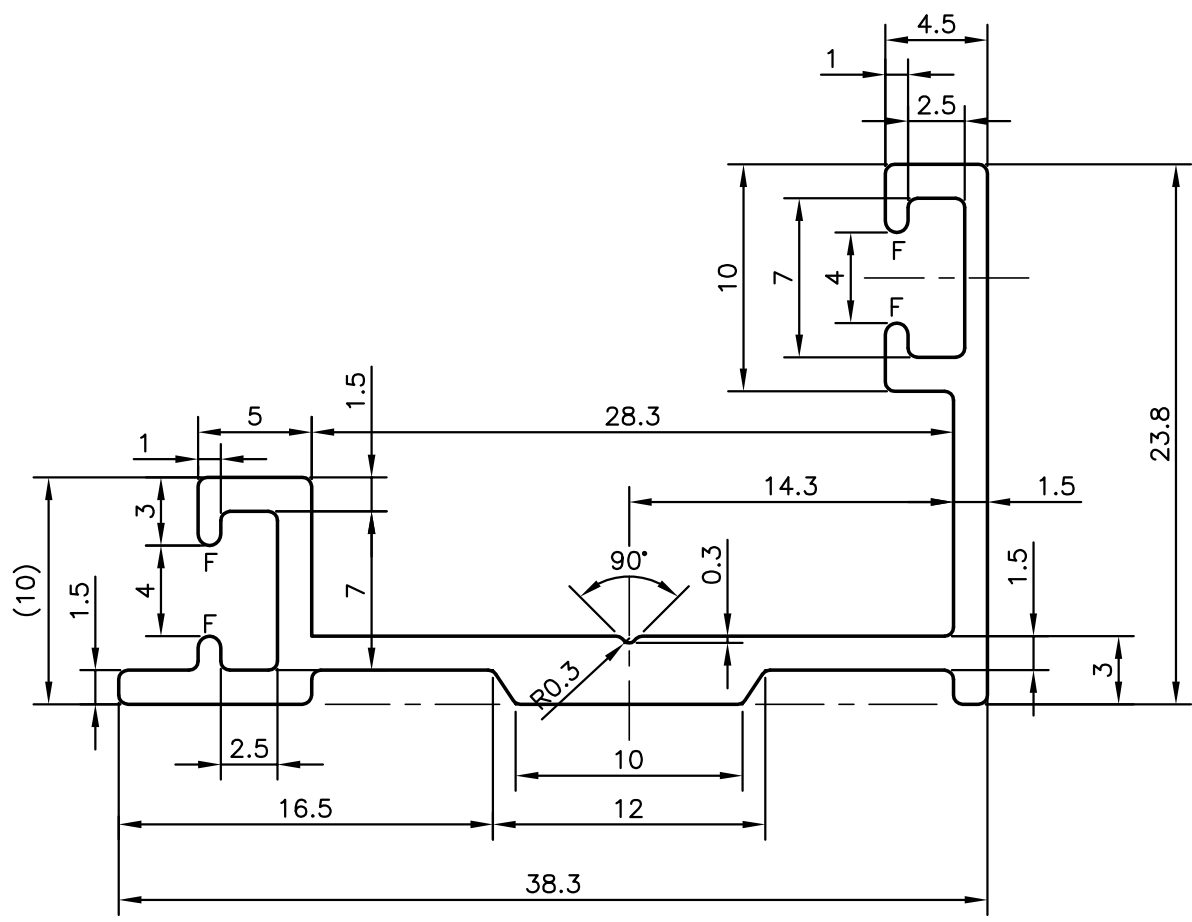

P-9607-1
S2374
35630

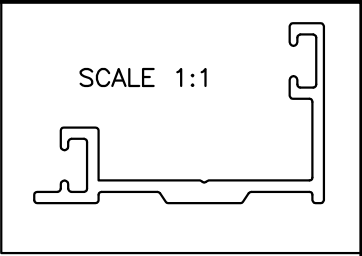

F = FILL RADIUS (4 PLACES)

 SYMBOL OF QUALITY AN ISO 9001 COMPANY	JINDAL ALUMINIUM LTD. BANGALORE-560073 (INDIA)	DRAWN	NAME	DATE
		CHECKED	RAGHAVENDRA	11-11-2009
1. ALL DIMENSIONS ARE IN mm. 2. ROUND OFF ALL SHARP CORNERS WITH 0.40 mm. 3. TOLERANCES WILL BE AS PERIS:3965-1981 UNLESS OTHERWISE SPECIFIED		APPROVED		
		SCALE		3:1
PARTY'S NAME S S FACADE PVT. LTD., GURGAON		AREA	mm ²	136.406
		PERIMETER	mm.	169.188
PARTY'S DRAWING No. AS PER DRAWING		WEIGHT	kg/m	0.368
		DRAWING No.	SECTION No.	
ALLOY & TEMPER 6063 T6		P-9607-1		-
		S2374		S2374
DESCRIPTION OPENABLE ADAPTER SECTION		35630		35630