

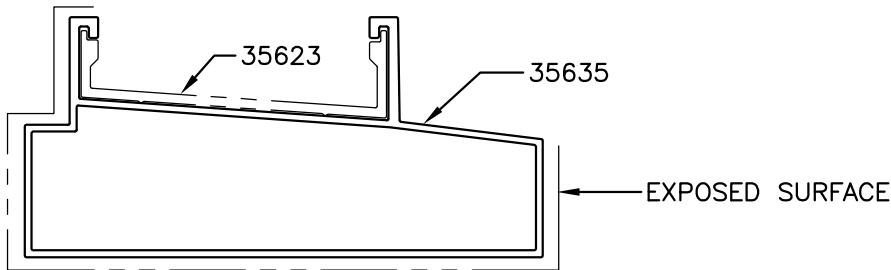

| |
|--------|
| P-9540 |
| S2350 |
| 35635 |

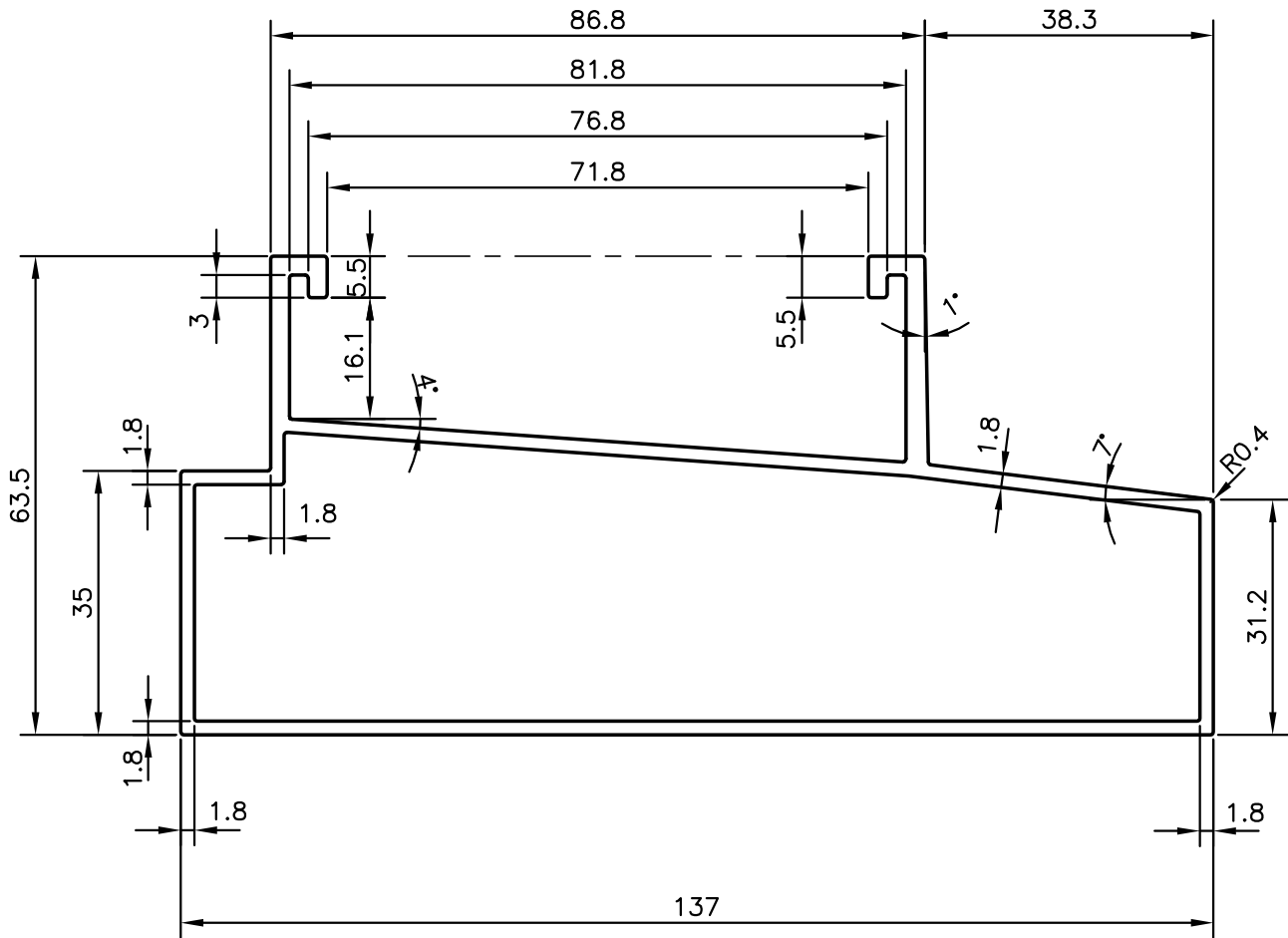

| | | | | | |
|--|--|---------------------------------------|-------------|----------------------|-------------|
|  SYMBOL OF QUALITY AN ISO 9001 COMPANY | JINDAL ALUMINIUM LTD. BANGALORE-560073 (INDIA) | DRAWN | J.P.KAUSHIK | NAME | DATE |
| | | CHECKED | | | 24-10-2009 |
| 1. ALL DIMENSIONS ARE IN mm. 2. ROUND OFF ALL SHARP CORNERS WITH 0.40 mm. 3. TOLERANCES WILL BE AS PER IS:6477-1983 UNLESS OTHERWISE SPECIFIED | | APPROVED | | | |
| PARTY'S NAME | | SP FABRICATORS PVT. LTD., NAVI MUMBAI | | SCALE | |
| PARTY'S DRAWING No. | | AL-615 | | 1:1 | |
| ALLOY & TEMPER | | 6063 T6 | | AREA mm ² | |
| DESCRIPTION | | UNITISED CURTAIN WALL SECTION | | 781.943 | |
| | | | | PERIMETER mm. | |
| | | | | 473.934 | |
| | | | | WEIGHT kg/m | |
| | | | | 2.111 | |
| | | | | DRAWING No. | SECTION No. |
| | | | | P-9540 | - |
| | | | | S2350 | S2350 |
| | | | | 35635 | 35635 |