

P-9648

S2388

35638

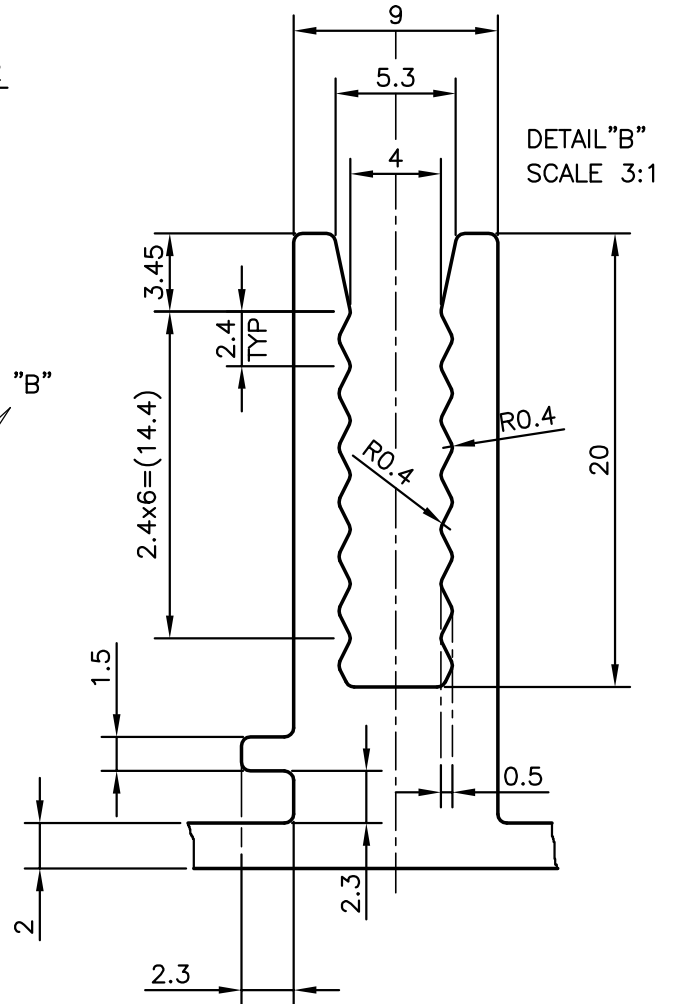
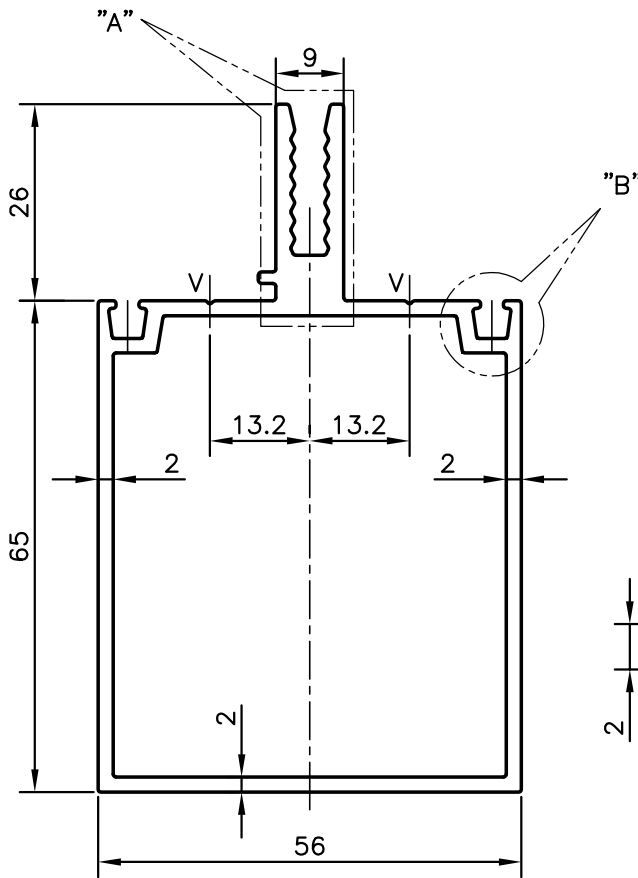
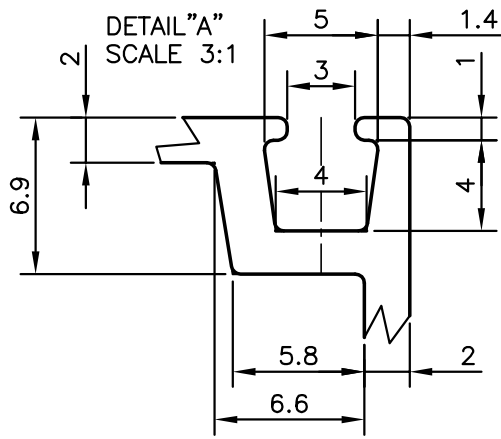

"V" = VEE GROOVE (0.40x90°) (2 PLACES)



SYMBOL OF QUALITY
AN ISO 9001 COMPANY

JINDAL ALUMINIUM LTD.
BANGALORE-560073 (INDIA)

	NAME	DATE
DRAWN	RAGHAVENDRA	20-11-2009
CHECKED		
APPROVED		

1. ALL DIMENSIONS ARE IN mm.
2. ROUND OFF ALL SHARP CORNERS WITH 0.40 mm.
3. TOLERANCES WILL BE AS PERIS:6477-1983 UNLESS OTHERWISE SPECIFIED

SCALE	1:1
AREA mm ²	632.337
PERIMETER mm.	362.265
WEIGHT kg/m	1.707

PARTY'S NAME S S FACADE PVT. LTD., GURGAON

PARTY'S DRAWING No. AS PER DRAWING

ALLOY & TEMPER 6063 T6

DESCRIPTION TRANSOM SECTION

DRAWING No.	SECTION No.
P-9648	-
S2388	S2388
35638	35638