

P-9809-1

S2470

35640

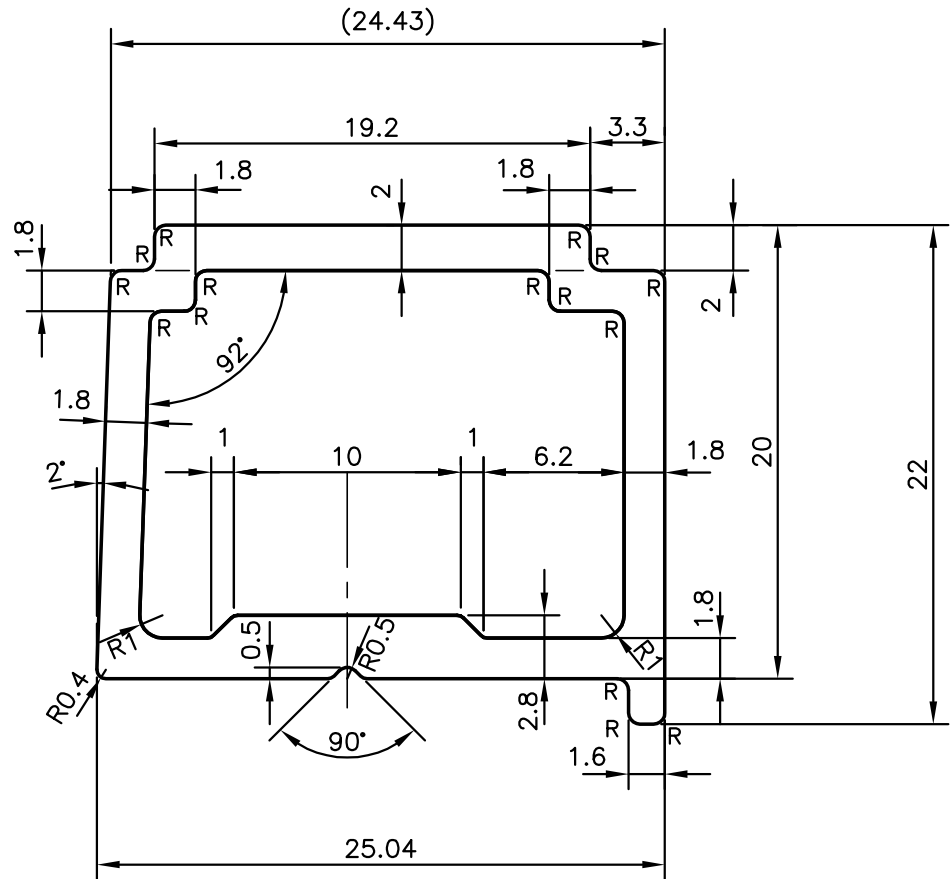
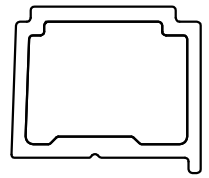

R = 0.5 RADIUS (15 PLACES)



SYMBOL OF QUALITY  
AN ISO 9001 COMPANY

**JINDAL ALUMINIUM LTD.**  
BANGALORE-560073 (INDIA)

|                      | NAME        | DATE       |
|----------------------|-------------|------------|
| DRAWN                | J.P.KAUSHIK | 23-02-2010 |
| CHECKED              |             |            |
| APPROVED             | S.S.GARG    | 02-03-2010 |
| SCALE                |             | 3:1        |
| AREA mm <sup>2</sup> |             | 165.343    |
| PERIMETER mm.        |             | 91.727     |
| WEIGHT kg/m          |             | 0.446      |
| DRAWING No.          | SECTION No. |            |
| P-9809-1             | -           |            |
| S2470                | S2470       |            |
| 35640                | 35640       |            |

1. ALL DIMENSIONS ARE IN mm.
2. ROUND OFF ALL SHARP CORNERS WITH 0.40 mm.
3. TOLERANCES WILL BE AS PERIS:6477-1983 UNLESS OTHERWISE SPECIFIED

|                     |                                |
|---------------------|--------------------------------|
| PARTY'S NAME        | ALUPLEX INDIA PVT. LTD.,MUMBAI |
| PARTY'S DRAWING No. | AP-1071                        |
| ALLOY & TEMPER      | HE9 WP                         |
| DESCRIPTION         | MISC. SECTION                  |