

P-11222

S3107

35644

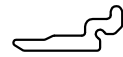

SCALE. -: 1:1

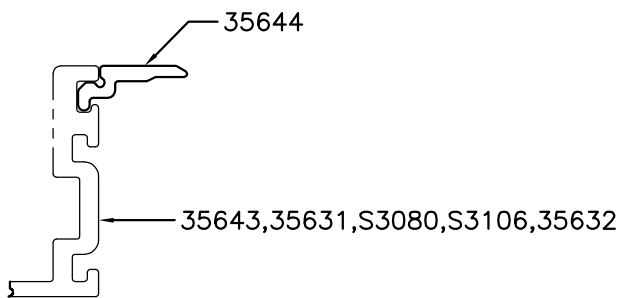
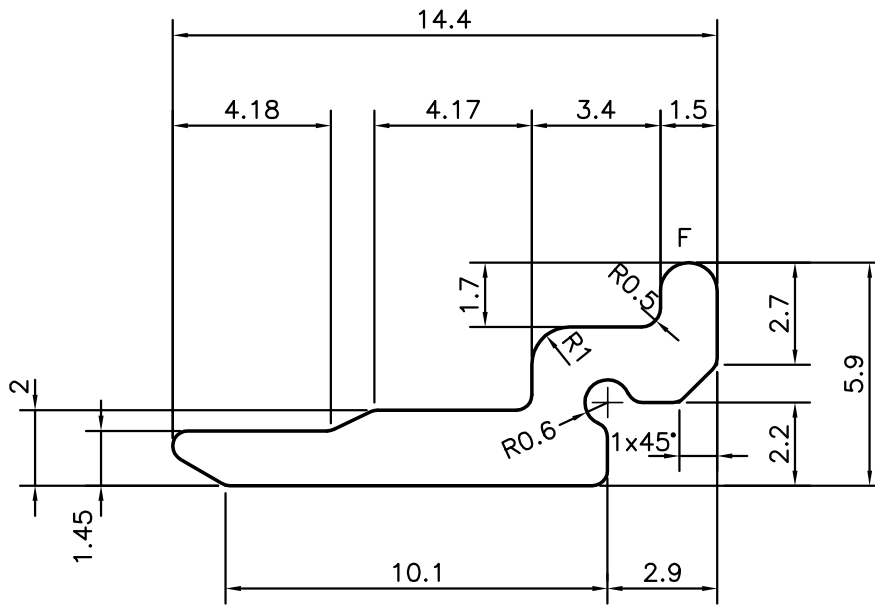

SYMBOL OF QUALITY
AN ISO 9001 COMPANY

JINDAL ALUMINIUM LTD.
BANGALORE-560073 (INDIA)

	NAME	DATE
DRAWN	PARVESH	23-09-2011
CHECKED		
APPROVED	S.S.GARG	24-11-2011
SCALE		5:1
AREA mm ²		30.727
PERIMETER mm.		38.525
WEIGHT kg/m		0.083
DRAWING No.	SECTION No.	
P-11222	-	
S3107	S3107	
35644	35644	

1. ALL DIMENSIONS ARE IN mm.
2. ROUND OFF ALL SHARP CORNERS WITH 0.40 mm.
3. TOLERANCES WILL BE AS PER, BS:EN-755-9 UNLESS OTHERWISE SPECIFIED

PARTY'S NAME	ALUMINIUM UDYOG, MANDI
PARTY'S DRAWING No.	5753
ALLOY & TEMPER	63400 WP
DESCRIPTION	CURTAIN WALL SECTION