

P-11651

35649

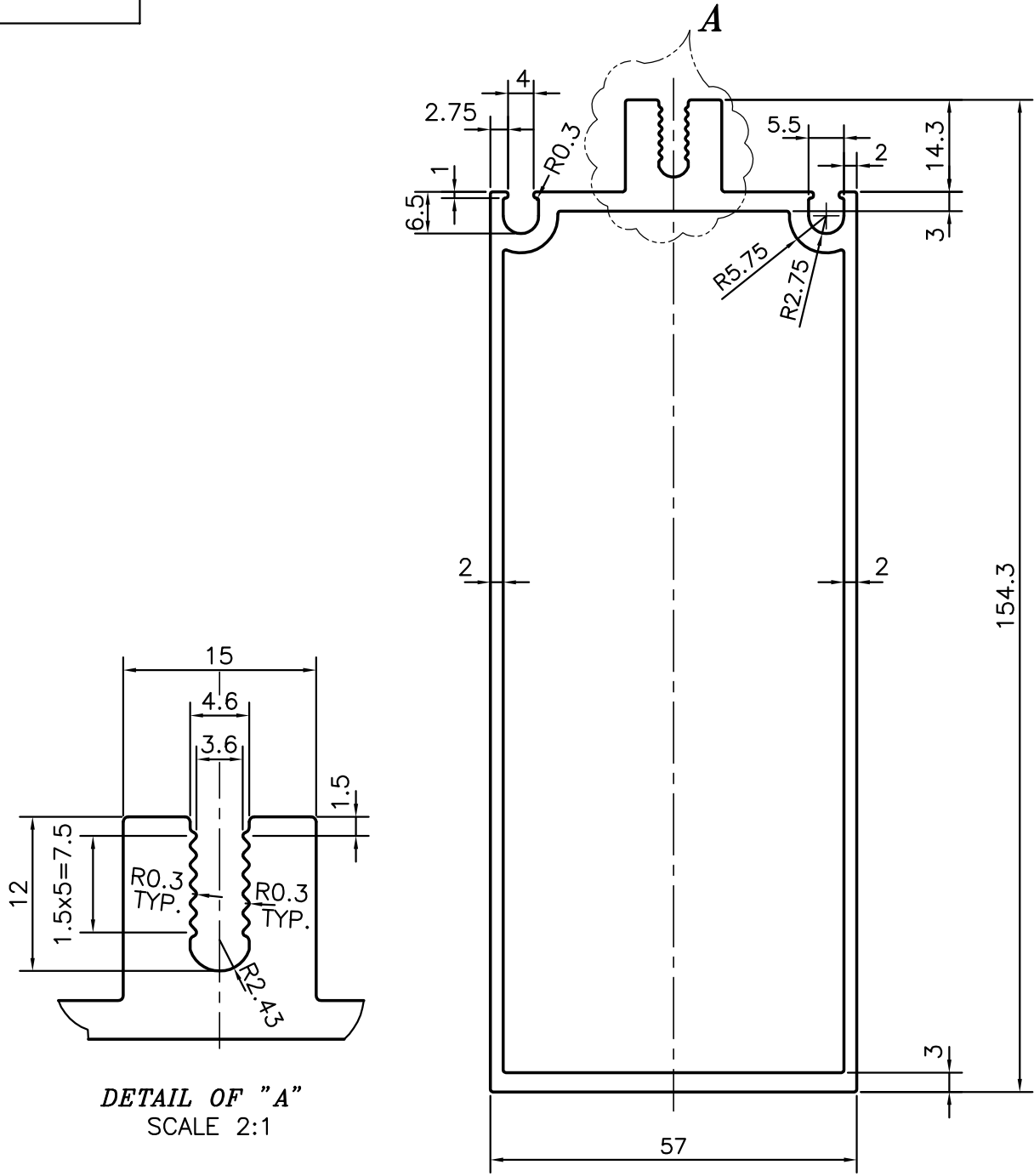

DETAIL OF "A"
SCALE 2:1



SYMBOL OF QUALITY
AN ISO 9001 COMPANY

JINDAL ALUMINIUM LTD.
BANGALORE-560073 (INDIA)

	NAME	DATE
DRAWN	PARVESH	09-04-2012
CHECKED		
APPROVED	S.S.GARG	17-04-2012
SCALE		1:1
AREA	mm ²	1076.696
PERIMETER	mm.	473.024
WEIGHT	kg/m	2.907
DRAWING No.	SECTION No.	
P-11651	-	
35649	35649	

1. ALL DIMENSIONS ARE IN mm.
2. ROUND OFF ALL SHARP CORNERS WITH 0.40 mm.
3. TOLERANCES WILL BE AS PER IS:6477-1983, UNLESS OTHERWISE SPECIFIED

PARTY'S NAME	GENERAL CATEGORY, DELHI MARKET
PARTY'S DRAWING No.	AS PER DRAWING
ALLOY & TEMPER	HE9 WP
DESCRIPTION	CURTAIN WALL SECTION