

| |
|--------|
| P-9732 |
| S2450 |
| 35652 |

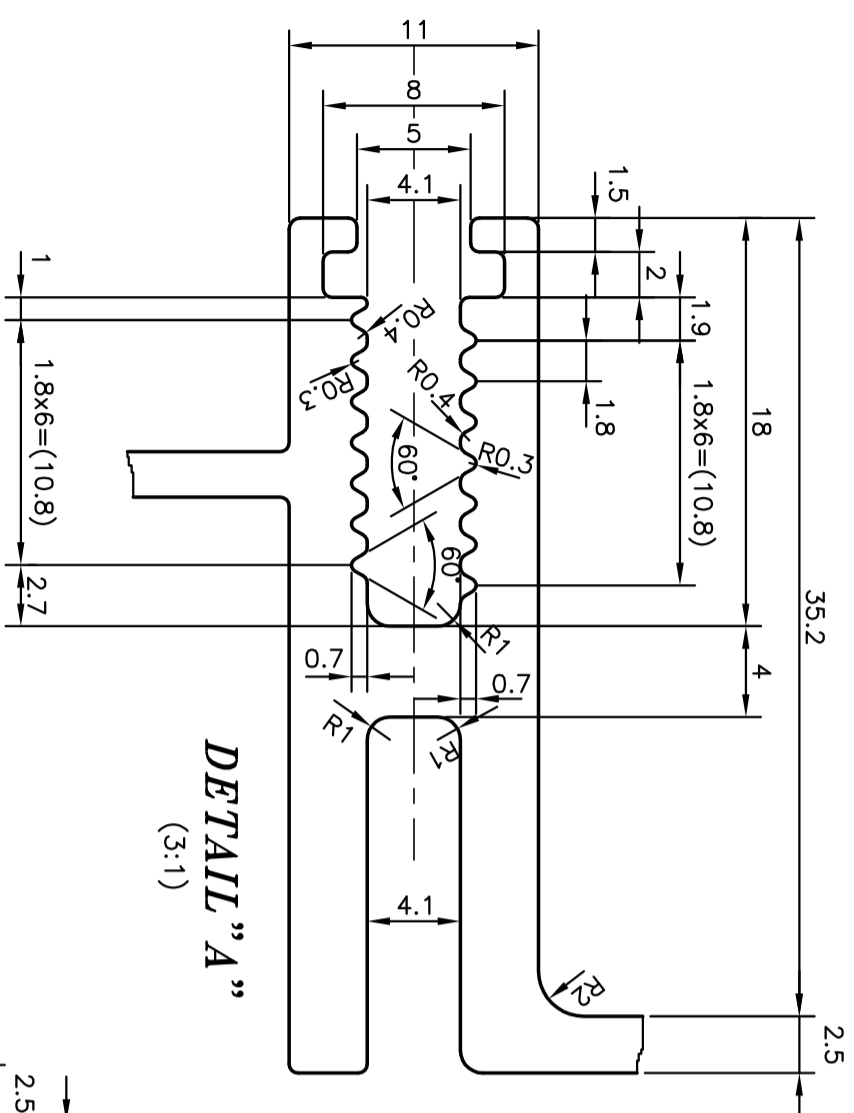

DETAIL "A"
(3:1)

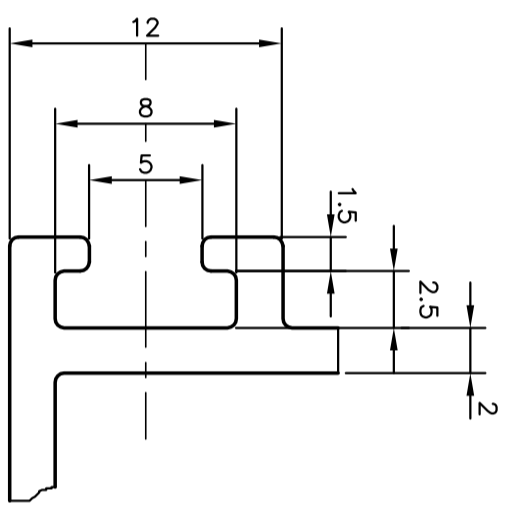

DETAIL "B"
(3:1)

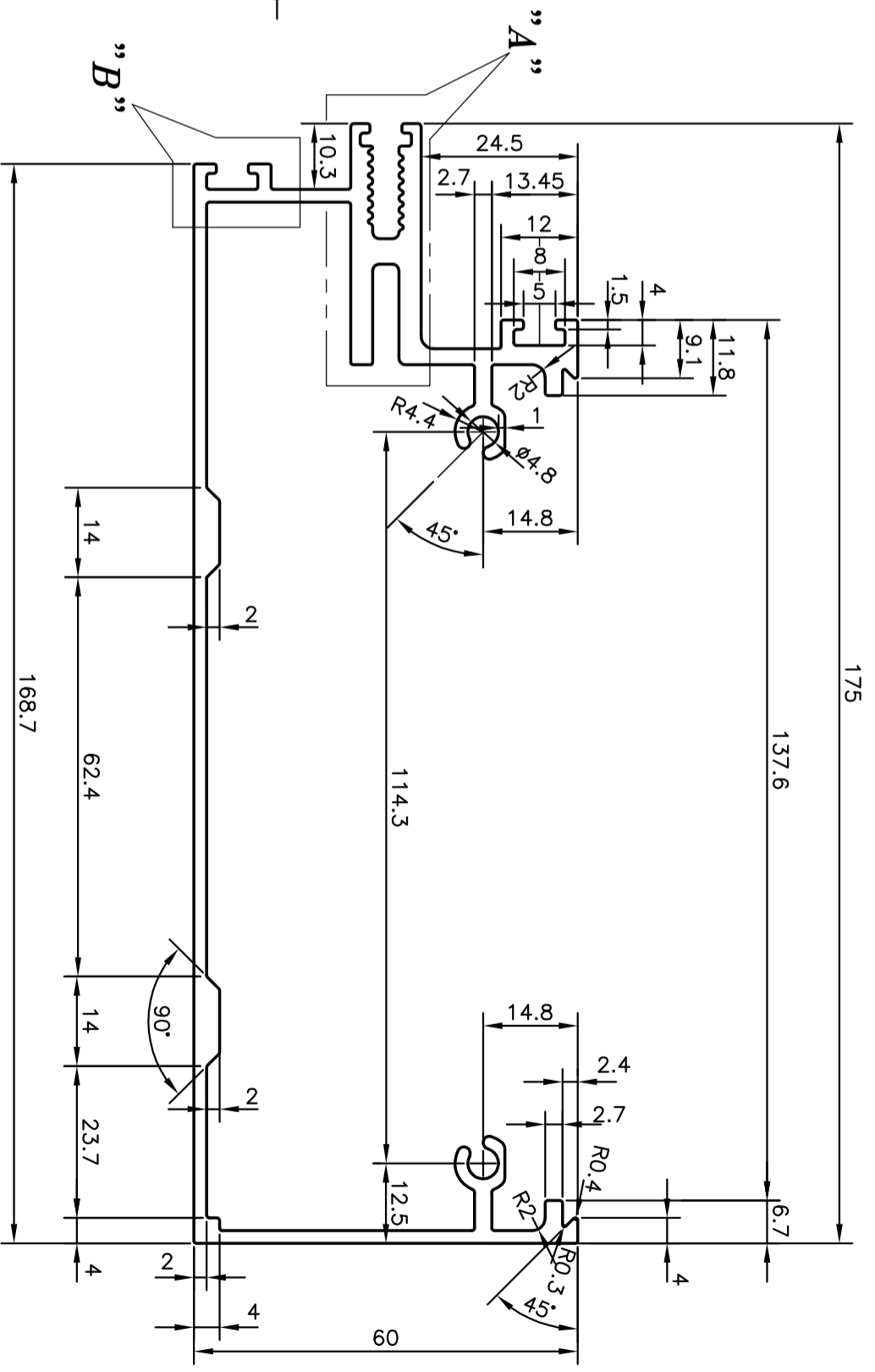

| | | | | |
|----------------------------------------------------------------------------------------------------------------------------------------------------------------|------------------------------------------------------------------|----------------------|---------------------|------------|
| <p>SYMBOL OF QUALITY AN ISO 9001 COMPANY</p> | <p>JINDAL ALUMINIUM LTD. BANGALORE-560073 (INDIA)</p> | | NAME | DATE |
| | | | J.P. KAUSHIK | 11-01-2010 |
| <p>1. ALL DIMENSIONS ARE IN mm. 2. ROUND OFF ALL SHARP CORNERS WITH 0.40 mm. 3. TOLERANCES WILL BE AS PER IS:3965-1981, UNLESS OTHERWISE SPECIFIED</p> | | CHECKED | | |
| <p>PARTY'S NAME SP FABRICATORS PVT. LTD., MUMBAI</p> | | APPROVED | S.S.GARG 17-02-2010 | |
| <p>PARTY'S DRAWING No. AL-591</p> | | SCALE | 1:1 | |
| <p>ALLOY & TEMPER 6063 T6</p> | | AREA mm ² | 1044.588 | |
| <p>DESCRIPTION JAMB MULLION SECTION</p> | | PERIMETER mm. | 868.45 | |
| | | WEIGHT kg/m | 2.820 | |
| | | DRAWING No. | SECTION No. | |
| | | P-9732 | - | |
| | | S2450 | S2450 | |
| | | 35652 | 35652 | |