

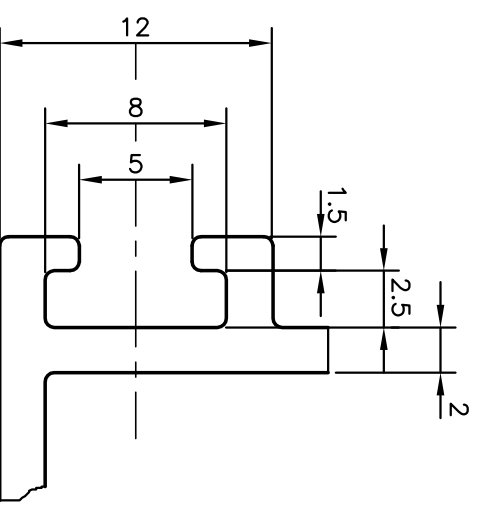

P-9759
S2453
35655

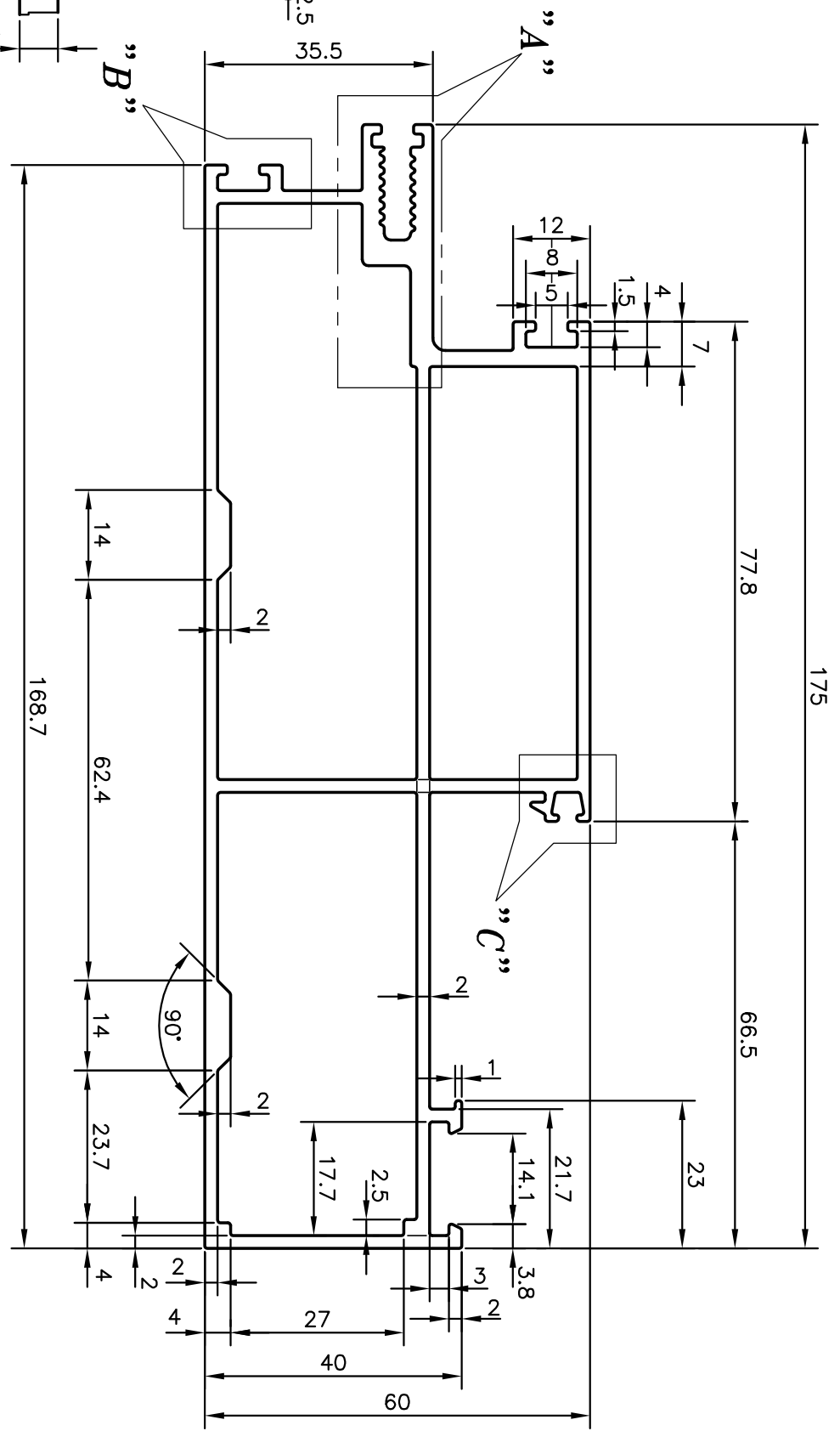
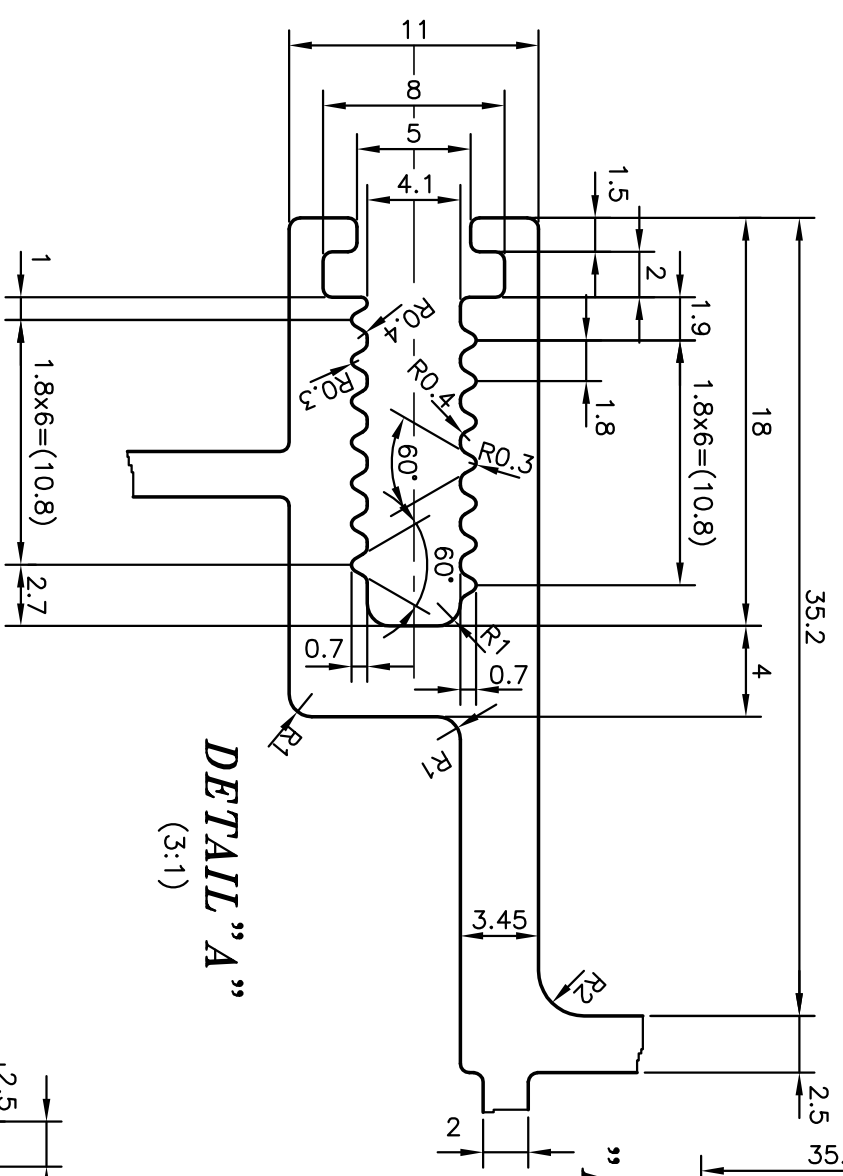
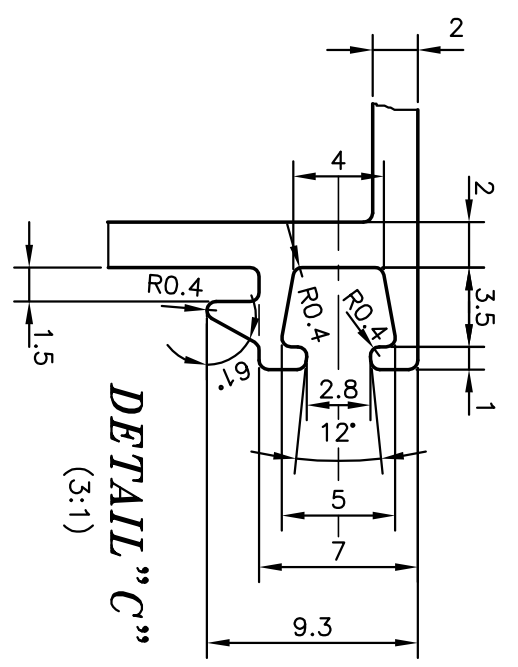

DETAIL "A"
(3:1)

DETAIL "C"
(3:1)

DETAIL "B"
(3:1)

 SYMBOL OF QUALITY AN ISO 9001 COMPANY	JINDAL ALUMINIUM LTD. BANGALORE-560073 (INDIA)		DRAWN J.P. KAUSHIK 23-01-2010
	1. ALL DIMENSIONS ARE IN mm. 2. ROUND OFF ALL SHARP CORNERS WITH 0.40 mm. 3. TOLERANCES WILL BE AS PER IS:6477-1983, UNLESS OTHERWISE SPECIFIED		CHECKED S.S.GARG 17-02-2010
PARTY'S NAME SP FABRICATORS PVT. LTD., MUMBAI	PARTY'S DRAWING No. AL-594	SCALE 1:1	AREA mm ² 1367.459
ALLOY & TEMPER 6063 T6	WEIGHT kg/m 3.692	PERIMETER mm. 607.601	SECTION No. 3.692
DESCRIPTION MULLION (GUTTER) SECTION	DRAWING No. P-9759 S2453 35655	SECTION No. - S2453 35655	