

P-9712-1

S2475

35660

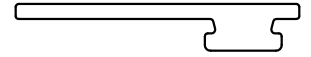

1:1

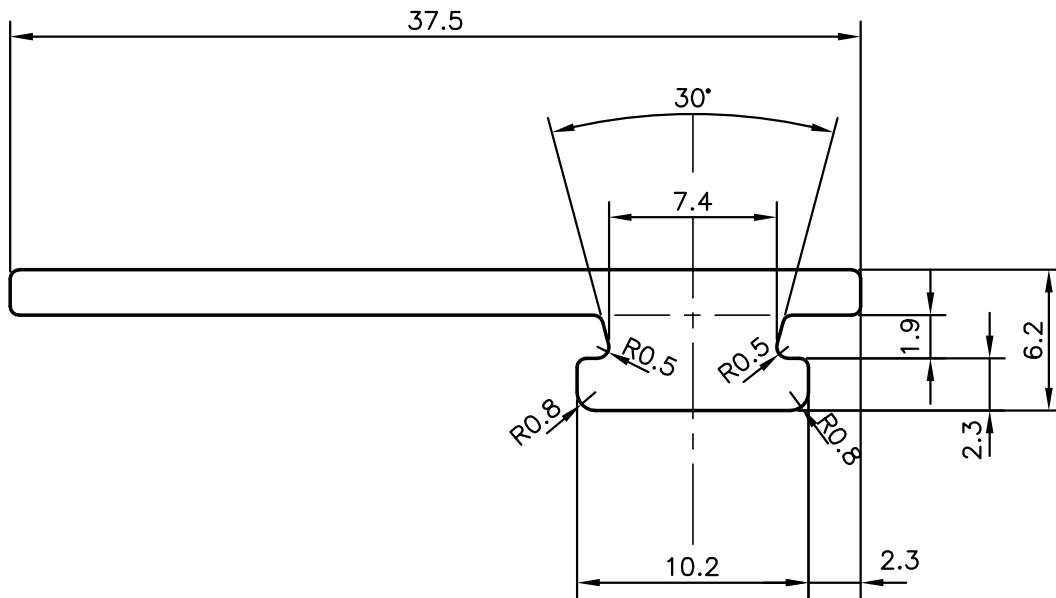
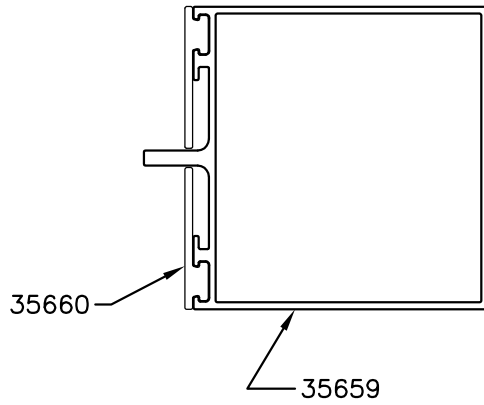

SYMBOL OF QUALITY
AN ISO 9001 COMPANY

JINDAL ALUMINIUM LTD.
BANGALORE-560073 (INDIA)

	NAME	DATE
DRAWN	J.P.KAUSHIK	04-02-2010
CHECKED		
APPROVED	S.S.GARG	03-03-2010

1. ALL DIMENSIONS ARE IN mm.
2. ROUND OFF ALL SHARP CORNERS WITH 0.40 mm.
3. TOLERANCES WILL BE AS PER IS:3965-1981, UNLESS OTHERWISE SPECIFIED

SCALE	3:1
AREA mm ²	112.66
PERIMETER mm.	90.051
WEIGHT kg/m	0.304

PARTY'S NAME	SP FABRICATORS PVT. LTD., MUMBAI
PARTY'S DRAWING No.	AL- 640
ALLOY & TEMPER	6063 T6
DESCRIPTION	ADAPTER PROFILE

DRAWING No.	SECTION No.
P-9712-1	-
S2475	S2475
35660	35660