

P-11810

S3369

35671

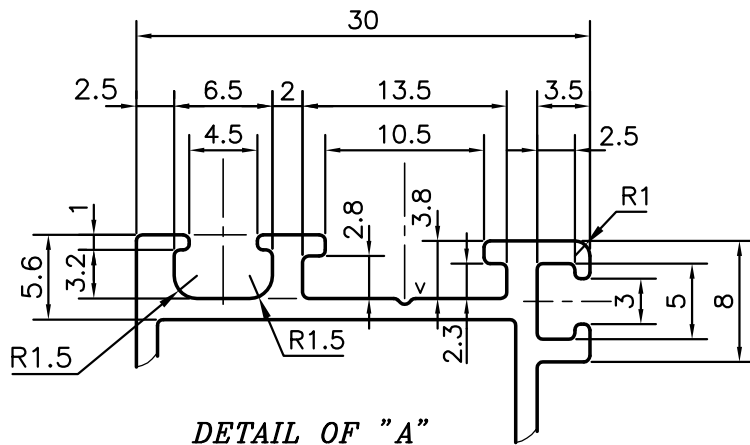
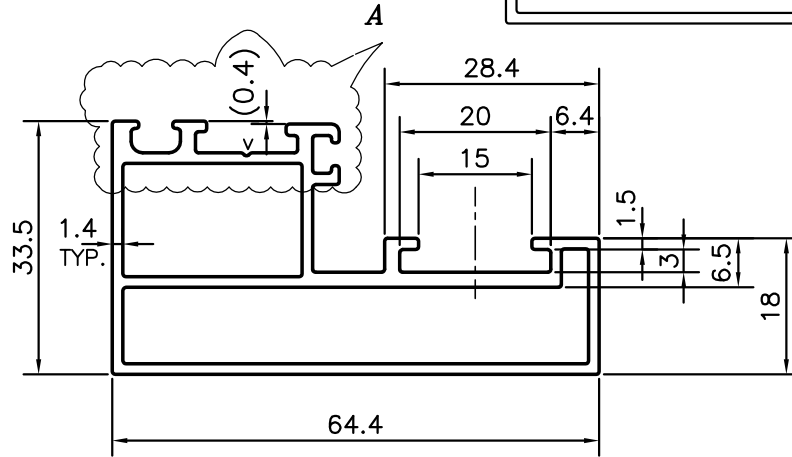
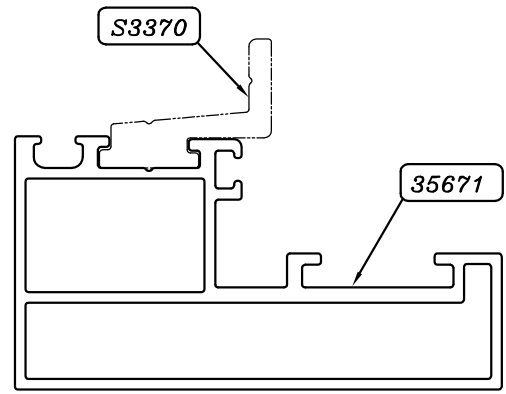

DETAIL OF "A"  
SCALE 2:1

V = VEE GROOVE 0.4x90°(1 PLACES)



SYMBOL OF QUALITY  
AN ISO 9001 COMPANY

**JINDAL ALUMINIUM LTD.**  
BANGALORE-560073 (INDIA)

	NAME	DATE
DRAWN	PARVESH	09-06-2012
CHECKED		
APPROVED	S.S.GARG	04-07-2012
SCALE		1:1
AREA mm <sup>2</sup>		383.292
PERIMETER mm.		259.65
WEIGHT kg/m		1.035
DRAWING No.	SECTION No.	
P-11810	-	
S3369	S3369	
35671	35671	

1. ALL DIMENSIONS ARE IN mm. 2. ROUND OFF ALL SHARP CORNERS WITH 0.40 mm. 3. TOLERANCES WILL BE AS PER IS:6477-1983, UNLESS OTHERWISE SPECIFIED	
PARTY'S NAME	HATIM GLAZING & CLADDING PVT. LTD., MUMBAI
PARTY'S DRAWING No.	ALU. DGU SASH SECTION
ALLOY & TEMPER	HE9 WP
DESCRIPTION	CURTAIN WALL SECTION