

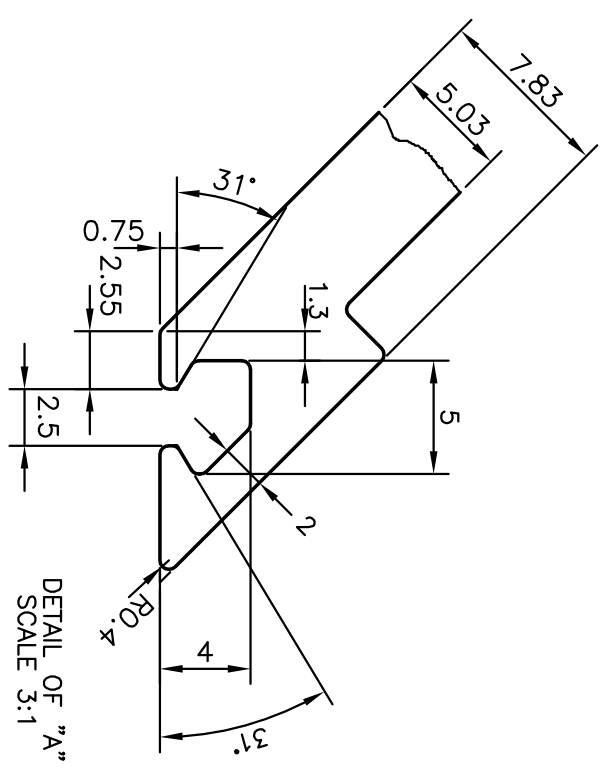

P-10278
S2651
35676

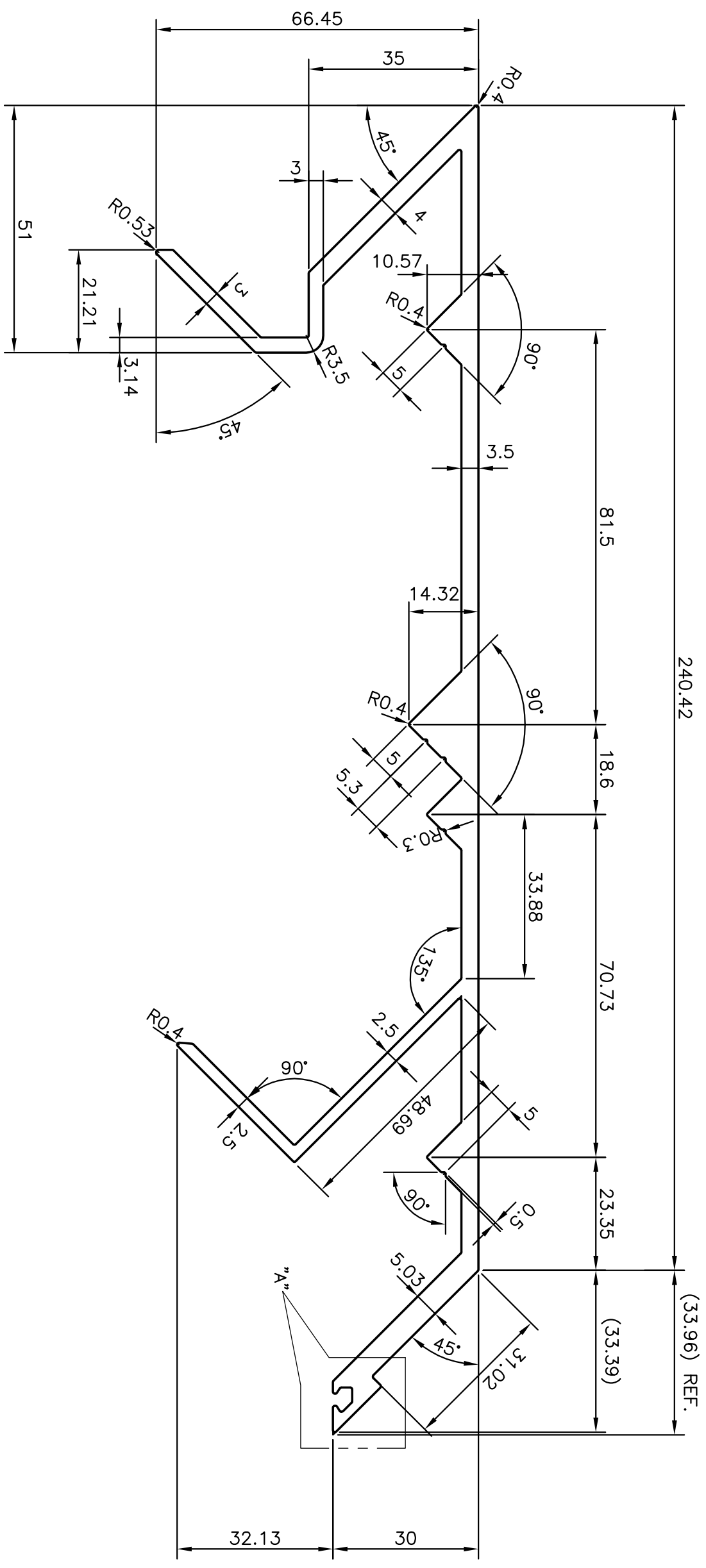

 <p>SYMBOL OF QUALITY AN ISO 9001 COMPANY</p>	<p>JINDAL ALUMINIUM LTD. BANGALORE-560073 (INDIA)</p>		NAME	DATE
	<p>1. ALL DIMENSIONS ARE IN mm. 2. ROUND OFF ALL SHARP CORNERS WITH 0.40 mm. 3. TOLERANCES WILL BE AS PER IS:3965-1981 UNLESS OTHERWISE SPECIFIED</p>		DRAWN	J.P. KAUSHIK 06-08-2010
PARTY'S NAME	GWS ENGINEERS & FABRICATORS PVT.LTD., MUMBAI	SCALE	1:1	
PARTY'S DRAWING No.	GWS-RE-DIE-01	AREA mm ²	1859.601	
ALLOY & TEMPER	HE9 WP	PERIMETER mm.	958.177	
DESCRIPTION	UNITIZED MALE MULLION	WEIGHT kg/m	5.021	
		DRAWING No.	SECTION No.	
		P-10278	-	
		S2651	S2651	
		35676	35676	