

P-10291
S2661
35678

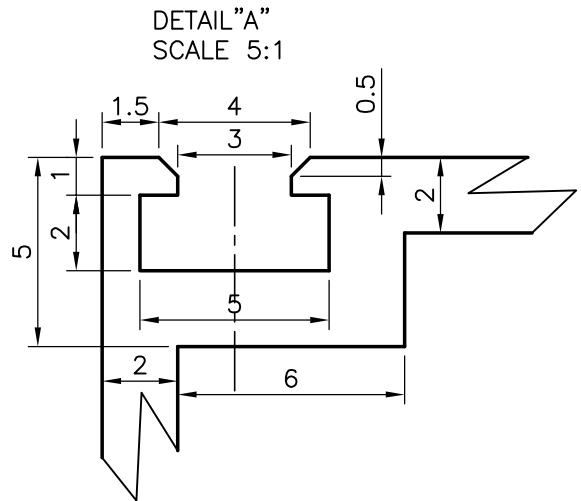
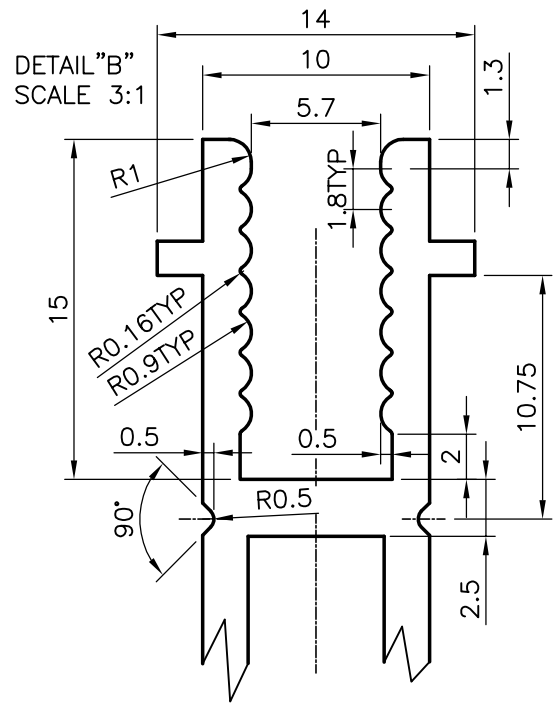
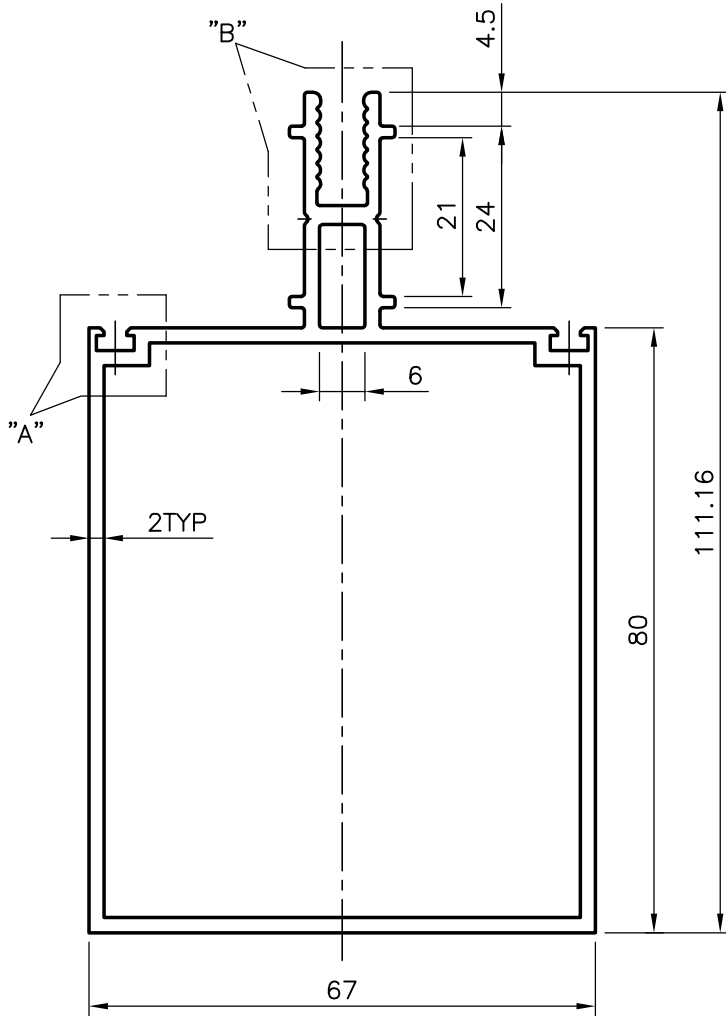

JINDAL ALUMINIUM LTD.
BANGALORE-560073 (INDIA)

	NAME	DATE
DRAWN	J.P.KAUSHIK	10-08-2010
CHECKED		
APPROVED	S.S.GARG	19-08-2010
SCALE		1:1
AREA mm ²		730.355
PERIMETER mm.		422.699
WEIGHT kg/m		1.972
DRAWING No.	SECTION No.	
P-10291	-	
S2661	S2661	
35678	35678	

1. ALL DIMENSIONS ARE IN mm.	
2. ROUND OFF ALL SHARP CORNERS WITH 0.40 mm.	
3. TOLERANCES WILL BE AS PER IS:6477-1983 UNLESS OTHERWISE SPECIFIED	
PARTY'S NAME	SUPERIOR HITECH CONTRACTORS PVT LTD., JAIPUR
PARTY'S DRAWING No.	AS PER DRAWING
ALLOY & TEMPER	HE9 WP
DESCRIPTION	CURTAIN WALL SECTION