

P-10184-1

S2658

35686

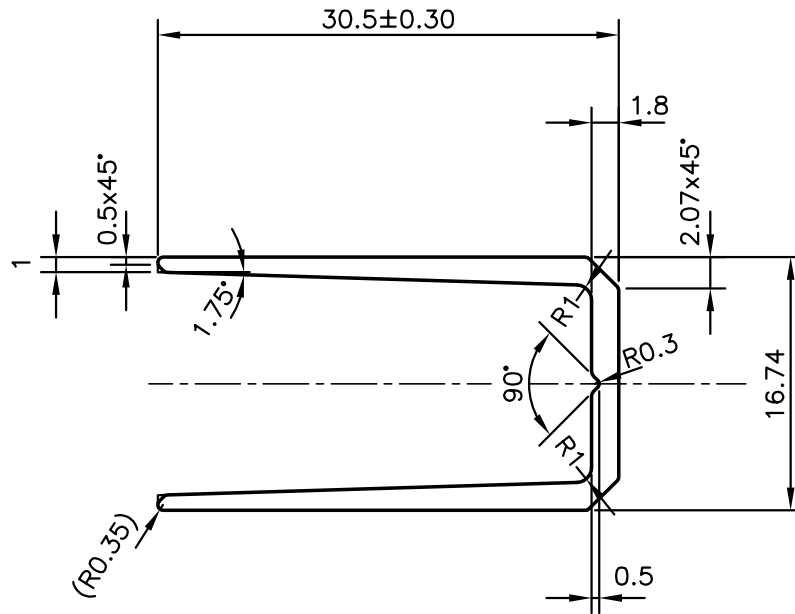
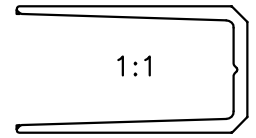

SYMBOL OF QUALITY  
AN ISO 9001 COMPANY

**JINDAL ALUMINIUM LTD.**  
BANGALORE-560073 (INDIA)

	NAME	DATE
DRAWN	J.P.KAUSHIK	31-07-2010
CHECKED		
APPROVED	S.S.GARG	18-08-2010
SCALE		2:1
AREA mm <sup>2</sup>		108.106
PERIMETER mm.		146.283
WEIGHT kg/m		0.292

1. ALL DIMENSIONS ARE IN mm.
2. ROUND OFF ALL SHARP CORNERS WITH 0.40 mm.
3. TOLERANCES WILL BE AS PER BS:EN-12020-2 UNLESS OTHERWISE SPECIFIED

PARTY'S NAME	INNOVATORS FACADE SYSTEMS PVT. LTD.,THANE	DRAWING No.	P-10184-1	SECTION No.	-
PARTY'S DRAWING No.	3000-15	S2658	S2658		
ALLOY & TEMPER	HE9 WP	35686	35686		
DESCRIPTION	MISC. CHANNEL				