

P-10185

S2659

35687

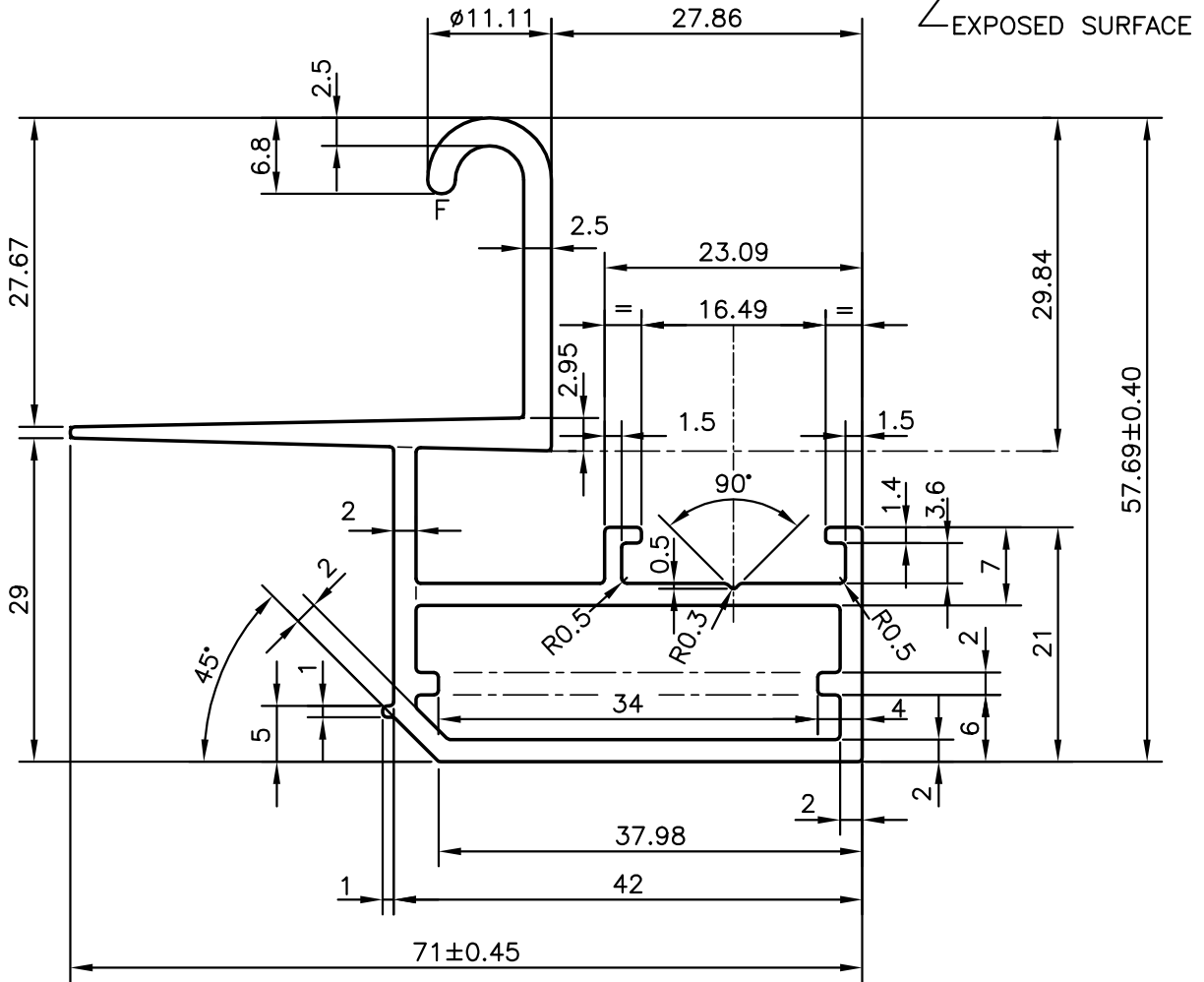
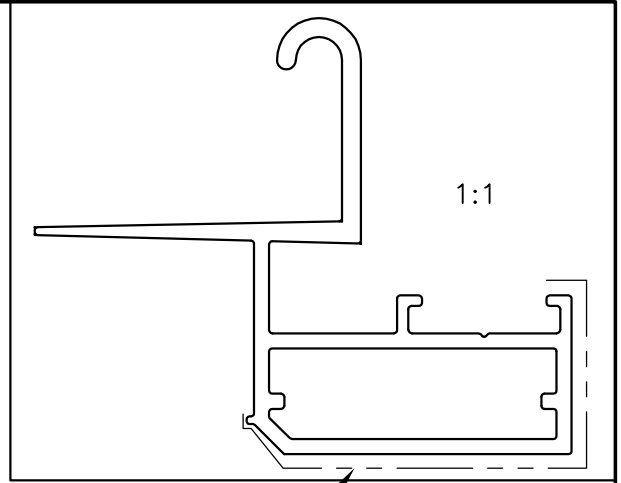

F = FULL RADIUS



SYMBOL OF QUALITY
AN ISO 9001 COMPANY

JINDAL ALUMINIUM LTD.
BANGALORE-560073 (INDIA)

	NAME	DATE
DRAWN	J.P.KAUSHIK	14-07-2010
CHECKED		
APPROVED	S.S.GARG	18-08-2010
SCALE		1.5:1
AREA mm ²		441.333
PERIMETER mm.		321.133
WEIGHT kg/m		1.192

1. ALL DIMENSIONS ARE IN mm.
2. ROUND OFF ALL SHARP CORNERS WITH 0.40 mm.
3. TOLERANCES WILL BE AS PER BS:EN-12020-2 UNLESS OTHERWISE SPECIFIED

PARTY'S NAME	INNOVATORS FACADE SYSTEMS PVT. LTD.,THANE	DRAWING No.	P-10185	SECTION No.	-
PARTY'S DRAWING No.	3000-17		S2659		S2659
ALLOY & TEMPER	HE9 WP		35687		35687
DESCRIPTION	CURTAIN WALL SECTION				