

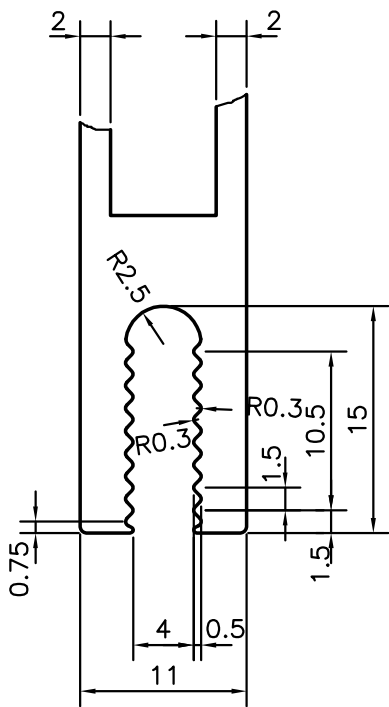

P-10540
S2767
35694

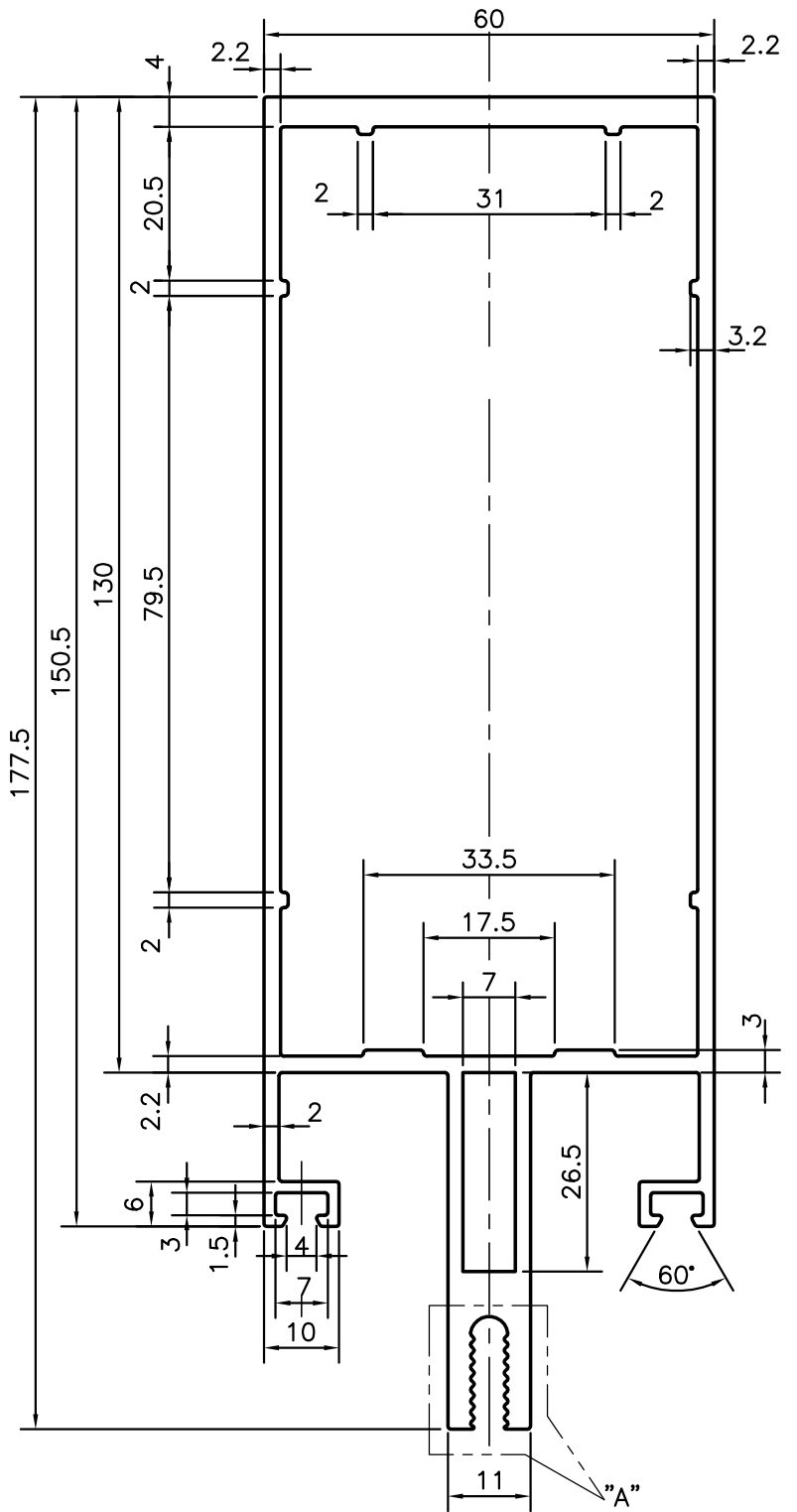

DETAIL OF "A"
SCALE 2:1



 SYMBOL OF QUALITY AN ISO 9001 COMPANY	JINDAL ALUMINIUM LTD. BANGALORE-560073 (INDIA)	NAME		DATE	
		DRAWN	J.P.KAUSHIK	30-10-2010	
1. ALL DIMENSIONS ARE IN mm. 2. ROUND OFF ALL SHARP CORNERS WITH 0.40 mm. 3. TOLERANCES WILL BE AS PER,IS:6477-1983 UNLESS OTHERWISE SPECIFIED		CHECKED			
		APPROVED		J.N.RAI	25-11-2010
PARTY'S NAME		ALUMILITE ARCHITECTURALS PVT. LTD., MUMBAI		SCALE	1:1
		PARTY'S DRAWING No.		1611	AREA mm ²
ALLOY & TEMPER		6063 T6		PERIMETER mm.	647.267
		DESCRIPTION		MULLION SECTION	WEIGHT kg/m
		DRAWING No.		SECTION No.	
		P-10540		-	
		S2767		S2767	
		35694		35694	