

P-10542

S2769

35696

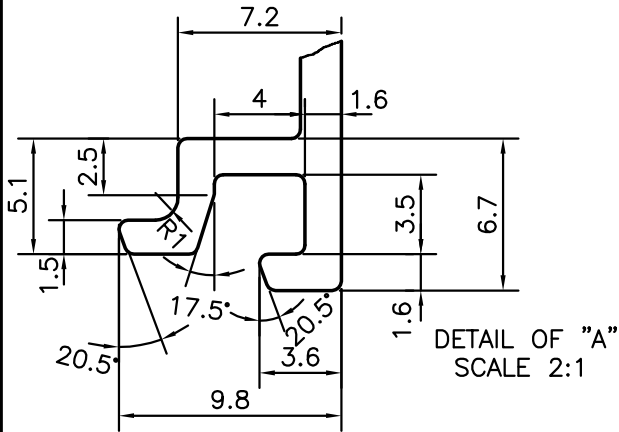
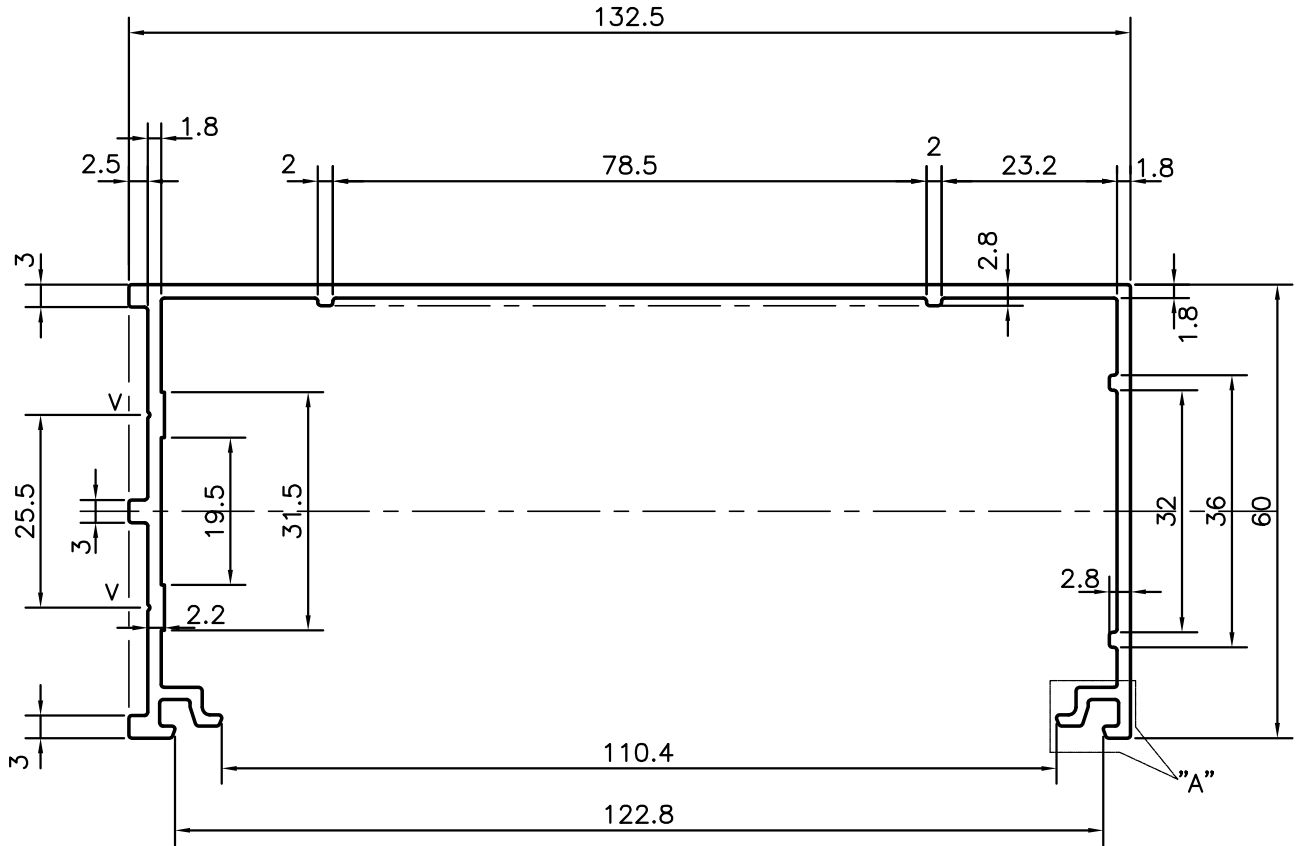
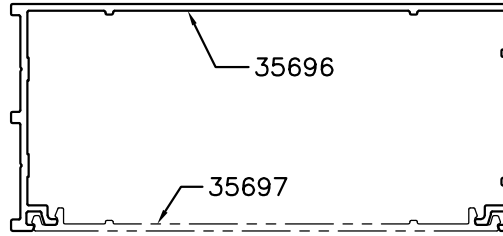

V = V GROOVE 0.30x90° (2 PLACES)



SYMBOL OF QUALITY  
AN ISO 9001 COMPANY

**JINDAL ALUMINIUM LTD.**  
BANGALORE-560073 (INDIA)

	NAME	DATE
DRAWN	J.P.KAUSHIK	02-11-2010
CHECKED		
APPROVED	J.N.RAI	25-11-2010
SCALE		1:1
AREA mm <sup>2</sup>		516.133
PERIMETER mm.		563.117
WEIGHT kg/m		1.394
DRAWING No.	SECTION No.	
P-10542	-	
S2769	S2769	
35696	35696	

1. ALL DIMENSIONS ARE IN mm.
2. ROUND OFF ALL SHARP CORNERS WITH 0.40 mm.
3. TOLERANCES WILL BE AS PER,IS:3965-1981 UNLESS OTHERWISE SPECIFIED

PARTY'S NAME	ALUMILITE ARCHITECTURALS PVT. LTD., MUMBAI
PARTY'S DRAWING No.	1613
ALLOY & TEMPER	6063 T6
DESCRIPTION	MISC. SECTION