

P-10528

S2789

35699

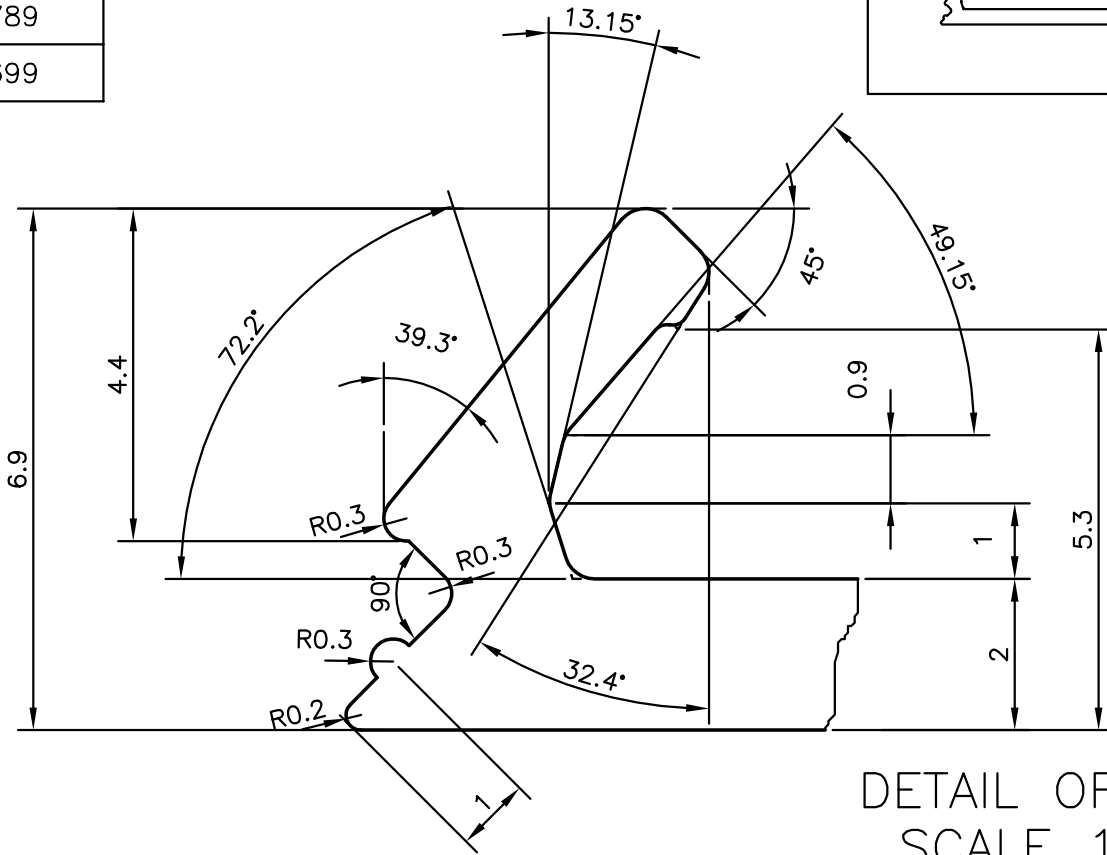
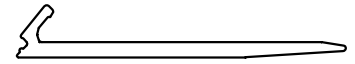

DETAIL OF "A"
SCALE 10:1

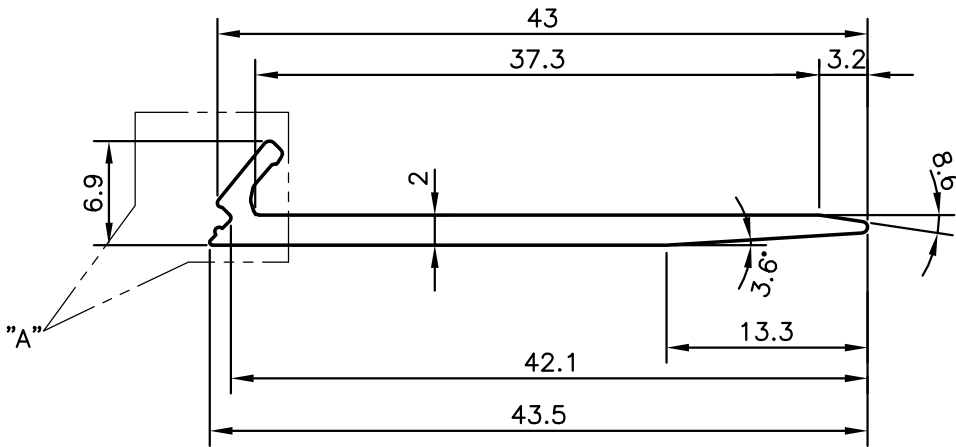

SYMBOL OF QUALITY
AN ISO 9001 COMPANY

JINDAL ALUMINIUM LTD.
BANGALORE-560073 (INDIA)

	NAME	DATE
DRAWN	J.P.KAUSHIK	27-10-2010
CHECKED		
APPROVED	J.N.RAI	08-12-2010

1. ALL DIMENSIONS ARE IN mm.
2. ROUND OFF ALL SHARP CORNERS WITH 0.40 mm.
3. TOLERANCES WILL BE AS PER IS:3965-1981 UNLESS OTHERWISE SPECIFIED

SCALE	2:1
AREA mm ²	87.817
PERIMETER mm.	100.919
WEIGHT kg/m	0.237

PARTY'S NAME	SP FABRICATORS PVT. LTD., MUMBAI
PARTY'S DRAWING No.	AL-760
ALLOY & TEMPER	6063 T6
DESCRIPTION	EDGE GARD FOR INWARD CORNER

DRAWING No.	SECTION No.
P-10528	-
S2789	S2789
35699	35699