

P-11856

S3380

35719

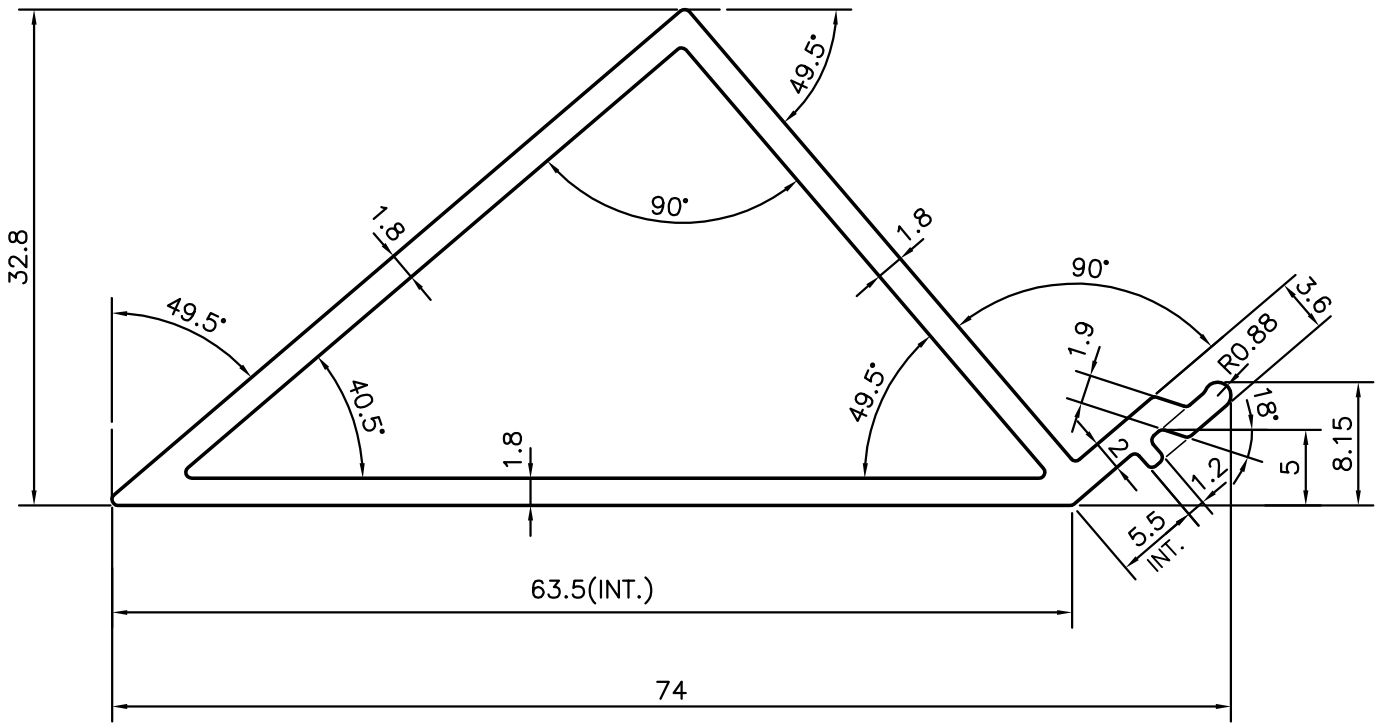
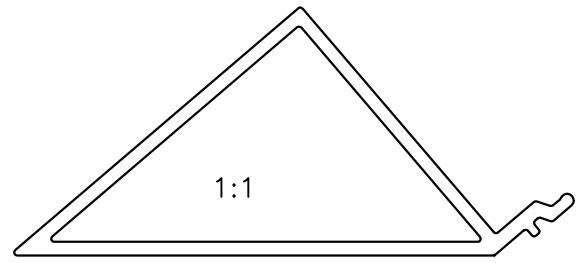

SYMBOL OF QUALITY
AN ISO 9001 COMPANY

JINDAL ALUMINIUM LTD.
BANGALORE-560073 (INDIA)

	NAME	DATE
DRAWN	J.P.KAUSHIK	22-06-2012
CHECKED		
APPROVED	S.S.GARG	05-07-2012

1. ALL DIMENSIONS ARE IN mm.
2. ROUND OFF ALL SHARP CORNERS WITH 0.40 mm.
3. TOLERANCES WILL BE AS PER,BS:EN-755-9 UNLESS OTHERWISE SPECIFIED

SCALE	2:1
AREA mm ²	293.169
PERIMETER mm.	182.359
WEIGHT kg/m	0.792

PARTY'S NAME	SP FABRICATOR PVT. LTD., MUMBAI	DRAWING No.	P-11856	SECTION No.	-
PARTY'S DRAWING No.	AL-846		S3380		S3380
ALLOY & TEMPER	6063 T6		35719		35719
DESCRIPTION	CURTAIN WALL SECTION-CORNER ADAPTER				