

P-11960

S3446

35741

EXPOSED SURFACE

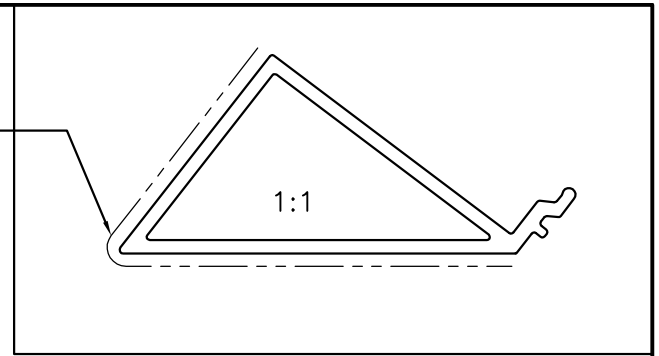

MATCHING SECTION No:- 35739

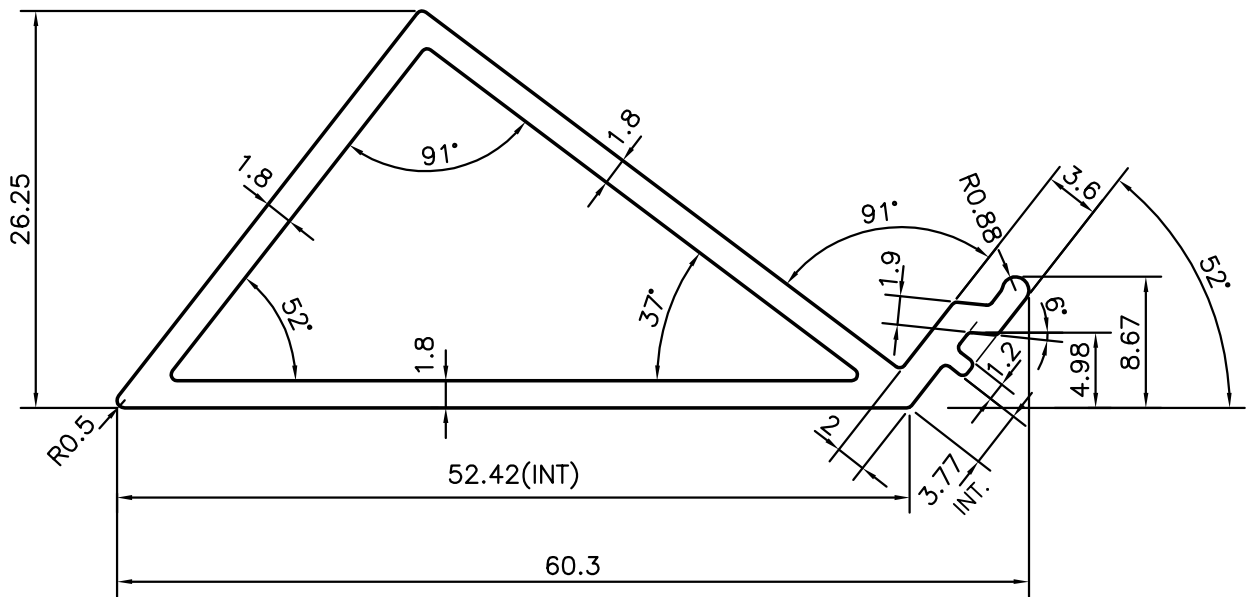

SYMBOL OF QUALITY  
AN ISO 9001 COMPANY

**JINDAL ALUMINIUM LTD.**  
BANGALORE-560073 (INDIA)

	NAME	DATE
DRAWN	J.P.KAUSHIK	11-08-2012
CHECKED		
APPROVED	S.S.GARG	22-08-2012

1. ALL DIMENSIONS ARE IN mm.
2. ROUND OFF ALL SHARP CORNERS WITH 0.40 mm.
3. TOLERANCES WILL BE AS PER,BS:EN-755-9 UNLESS OTHERWISE SPECIFIED

SCALE	2:1
AREA mm <sup>2</sup>	240.086
PERIMETER mm.	151.328
WEIGHT kg/m	0.648

PARTY'S NAME	SP FABRICATOR PVT. LTD., MUMBAI
PARTY'S DRAWING No.	AL-854
ALLOY & TEMPER	6063 T6
DESCRIPTION	CURTAIN WALL SECTION-CORNER ADAPTER

DRAWING No.	SECTION No.
P-11960	-
S3446	S3446
35741	35741