

P-11963

S3449

35744

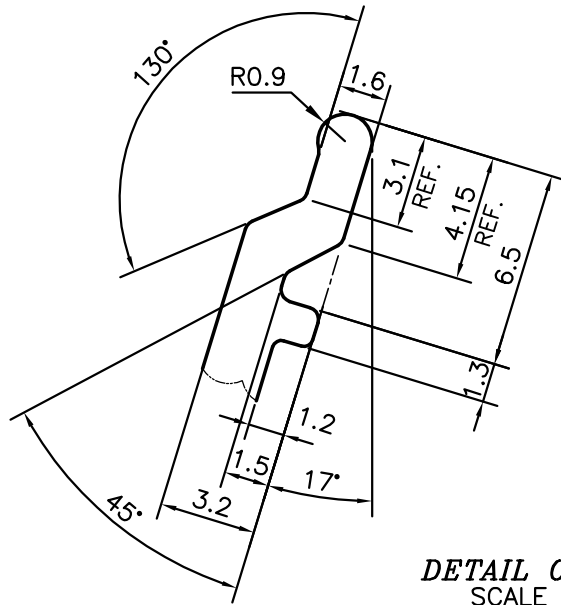
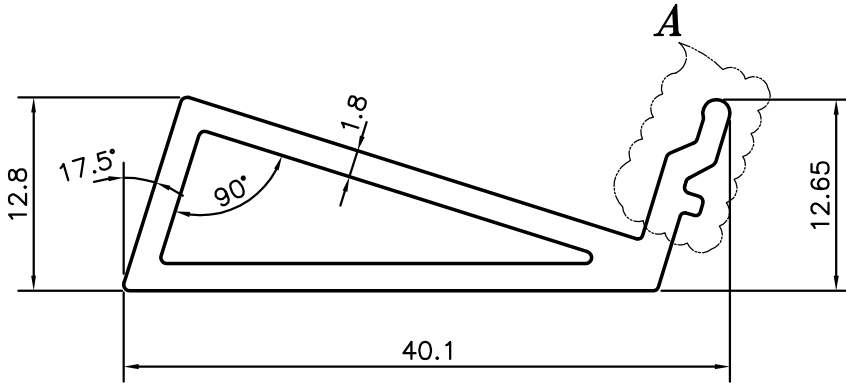
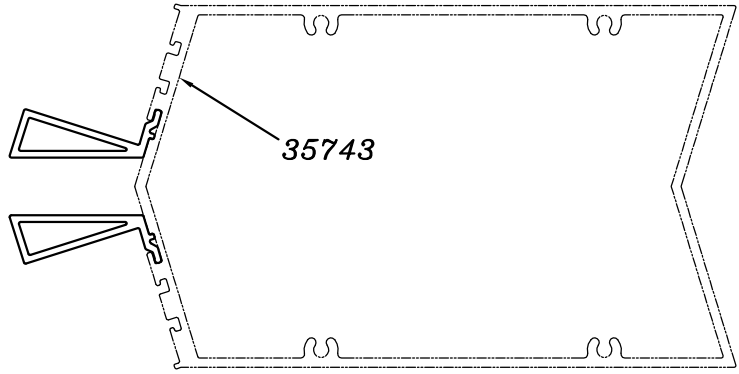

DETAIL OF "A"
SCALE 4:1

EXPOSED SURFACE

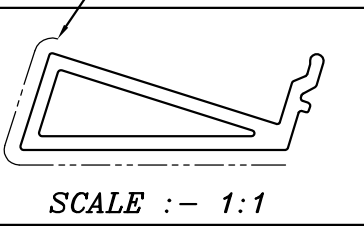

SCALE :- 1:1



SYMBOL OF QUALITY
AN ISO 9001 COMPANY

JINDAL ALUMINIUM LTD.
BANGALORE-560073 (INDIA)

	NAME	DATE
DRAWN	PARVESH	11-08-2012
CHECKED		
APPROVED	S.S.GARG	22-08-2012
SCALE		2:1
AREA mm ²		163.196
PERIMETER mm.		108.156
WEIGHT kg/m		0.441
DRAWING No.	SECTION No.	
P-11963	-	
S3449	S3449	
35744	35744	

1. ALL DIMENSIONS ARE IN mm.
2. ROUND OFF ALL SHARP CORNERS WITH 0.40 mm.
3. TOLERANCES WILL BE AS PER BS:EN-755-9, UNLESS OTHERWISE SPECIFIED

PARTY'S NAME	SP FABRICATORS PVT. LTD., MUMBAI
PARTY'S DRAWING No.	AL-848
ALLOY & TEMPER	6063 T6
DESCRIPTION	CURTAIN WALL SECTION - CORNER ADAPTOR