

P-11964
S3450
35745

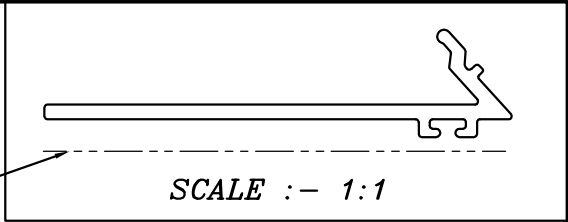

EXPOSED SURFACE

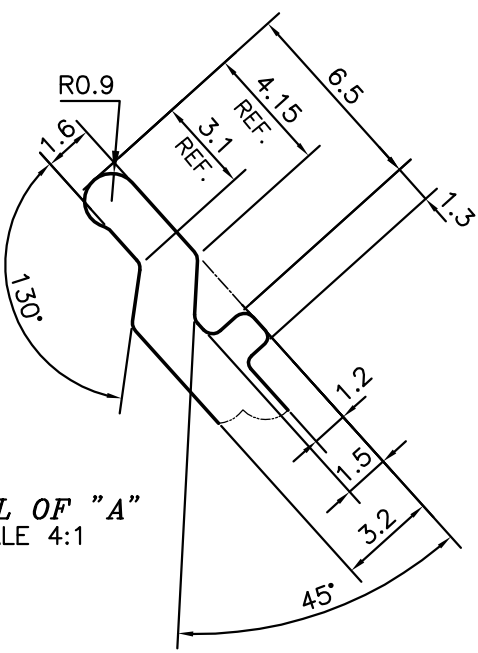
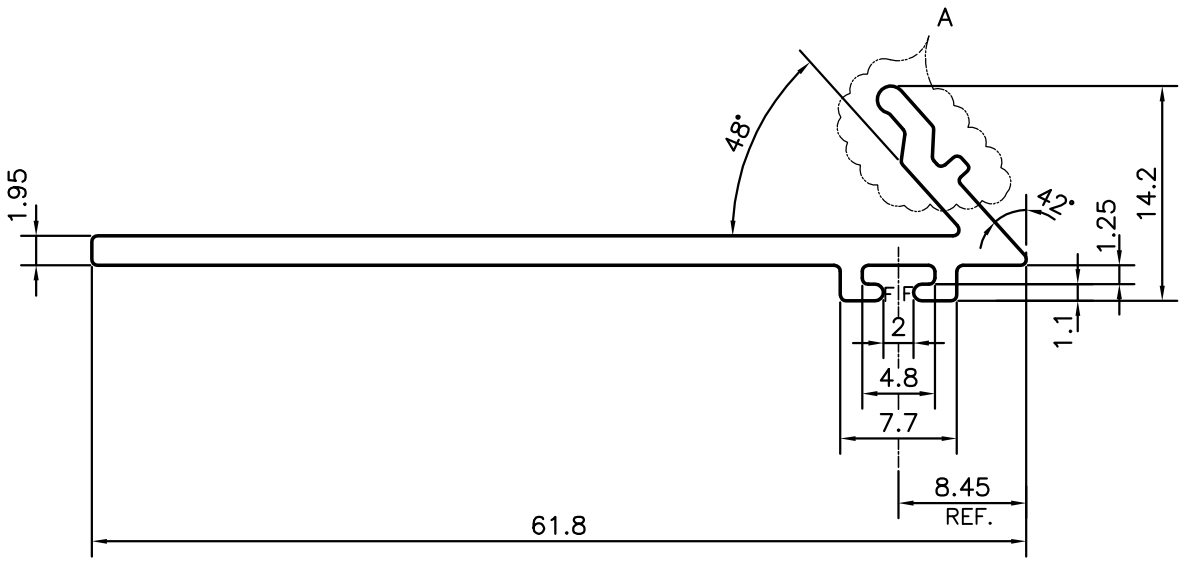

DETAIL OF "A"
SCALE 4:1

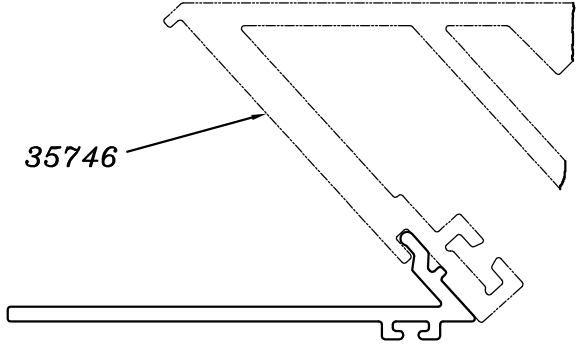

F = FULL RADIUS (2 PLACES)

 SYMBOL OF QUALITY AN ISO 9001 COMPANY	JINDAL ALUMINIUM LTD. BANGALORE-560073 (INDIA)	NAME	DATE
		DRAWN	PARVESH 11-08-2012
		CHECKED	
		APPROVED	S.S.GARG 22-08-2012
		SCALE	2:1
		AREA mm ²	153.991
		PERIMETER mm.	163.444
		WEIGHT kg/m	0.416
		DRAWING No.	SECTION No.
		P-11964	-
		S3450	S3450
		35745	35745
PARTY'S NAME	SP FABRICATORS PVT. LTD., MUMBAI		
PARTY'S DRAWING No.	AL-851		
ALLOY & TEMPER	6063 T6		
DESCRIPTION	CURTAIN WALL SECTION - GLASS ADAPTOR		