

P-10937-1

S2926

35757

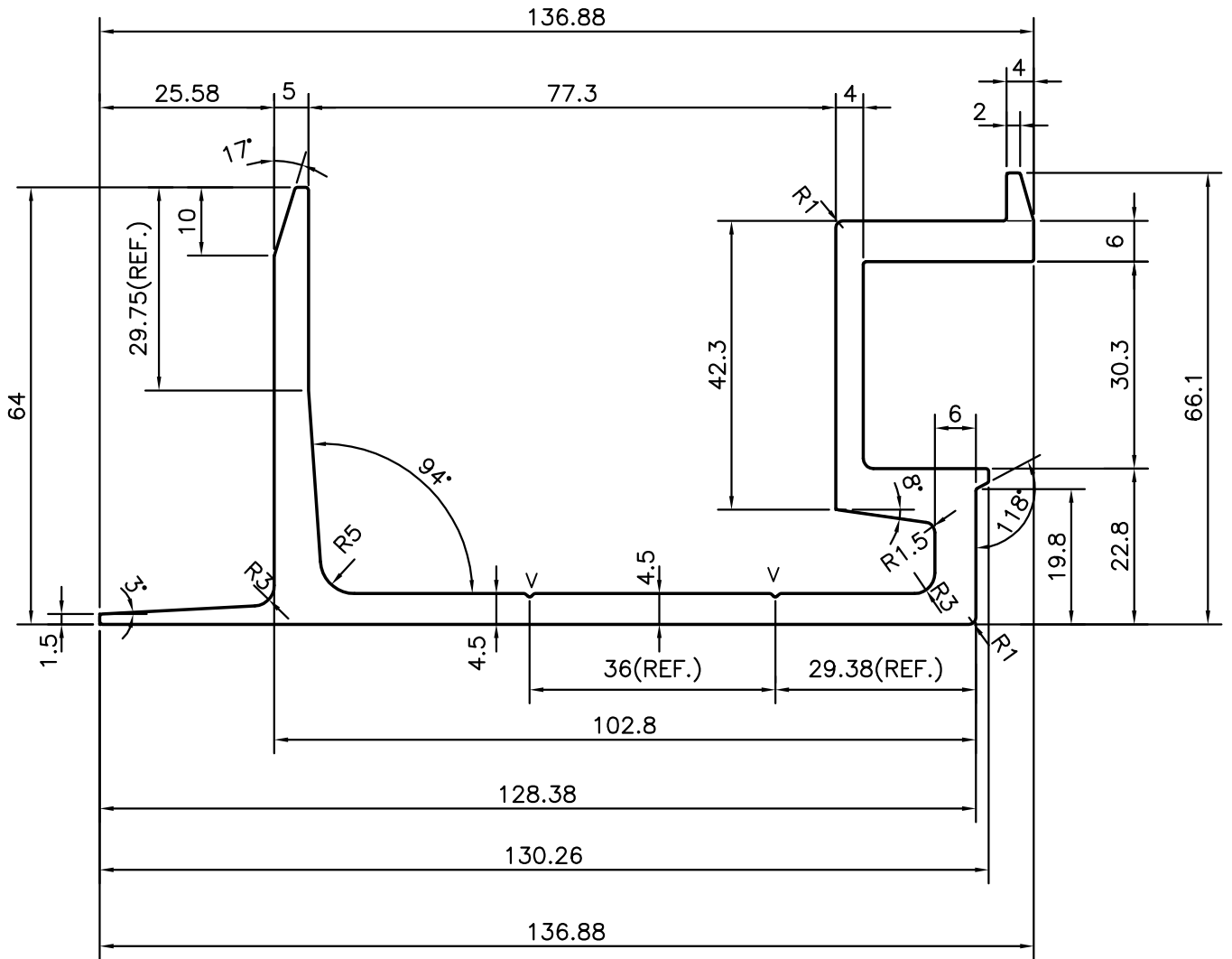

V = V GROOVE 0.5x45° (2 PLACES)



SYMBOL OF QUALITY
AN ISO 9001 COMPANY

JINDAL ALUMINIUM LTD.
BANGALORE-560073 (INDIA)

	NAME	DATE
DRAWN	J.P.KAUSHIK	14-05-2011
CHECKED		
APPROVED	S.S.GARG	19-05-2011

1. ALL DIMENSIONS ARE IN mm.
2. ROUND OFF ALL SHARP CORNERS WITH 0.40 mm.
3. TOLERANCES WILL BE AS PER IS:3965-1981 UNLESS OTHERWISE SPECIFIED

SCALE	1:1
AREA mm ²	1371.307
PERIMETER mm.	573.174
WEIGHT kg/m	3.703

PARTY'S NAME	ALUMINIUM IINNOVATIONS, BANGALORE
PARTY'S DRAWING No.	AS PER DRAWING
ALLOY & TEMPER	63400 WP
DESCRIPTION	CURTAIN WALL SECTION

DRAWING No.	SECTION No.
P-10937-1	-
S2926	S2926
35757	35757