

P-10938-1

S2927

35758

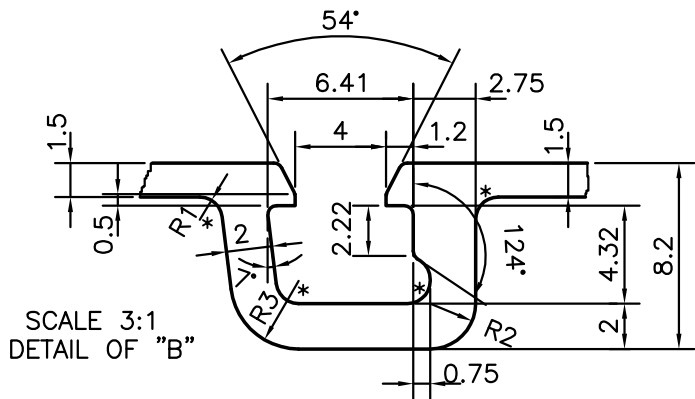
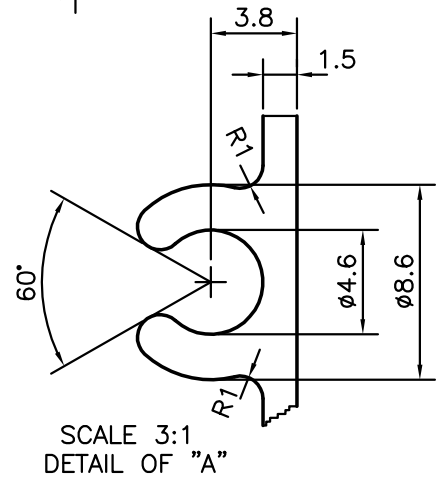
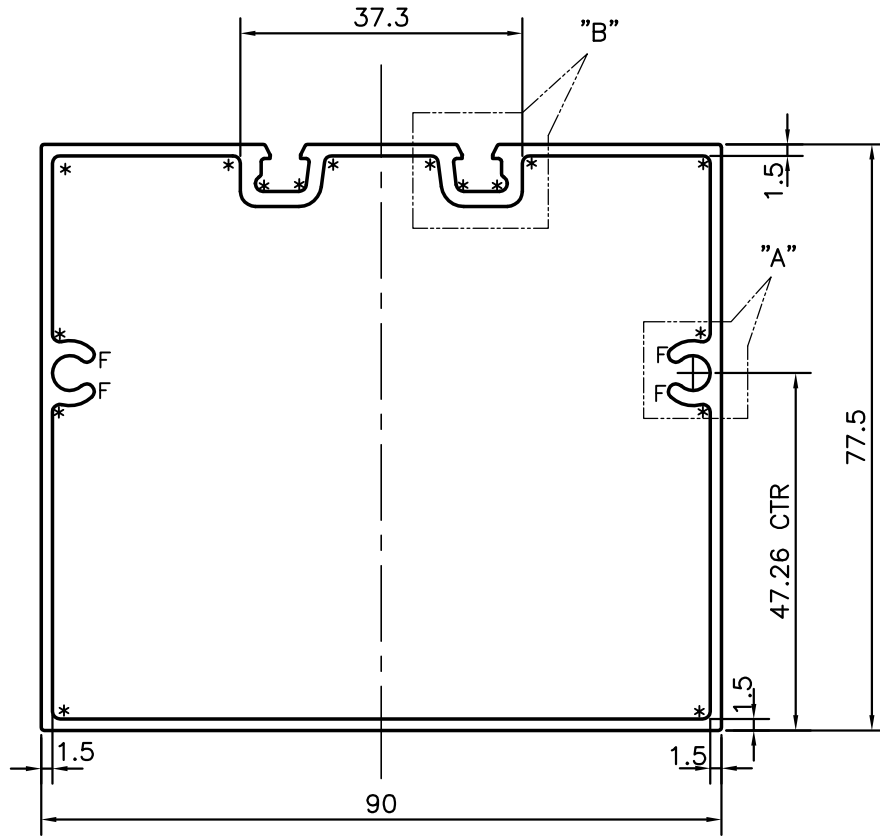

* = 1.0 RADIUS (16 PLACES)
 F = FULL RADIUS (4 PLACES)



SYMBOL OF QUALITY
 AN ISO 9001 COMPANY

JINDAL ALUMINIUM LTD.
 BANGALORE-560073 (INDIA)

	NAME	DATE
DRAWN	J.P.KAUSHIK	14-05-2011
CHECKED		
APPROVED	S.S.GARG	19-05-2011
SCALE		1:1
AREA mm ²		612.055
PERIMETER mm.		365.183
WEIGHT kg/m		1.653
DRAWING No.	SECTION No.	
P-10938-1	-	
S2927	S2927	
35758	35758	

1. ALL DIMENSIONS ARE IN mm.
2. ROUND OFF ALL SHARP CORNERS WITH 0.40 mm.
3. TOLERANCES WILL BE AS PER IS:6477-1983 UNLESS OTHERWISE SPECIFIED

PARTY'S NAME	ALUMINIUM IINNOVATIONS, BANGALORE
PARTY'S DRAWING No.	AS PER DRAWING
ALLOY & TEMPER	63400 WP
DESCRIPTION	CURTAIN WALL SECTION