

P-10240-2

S2650

35775

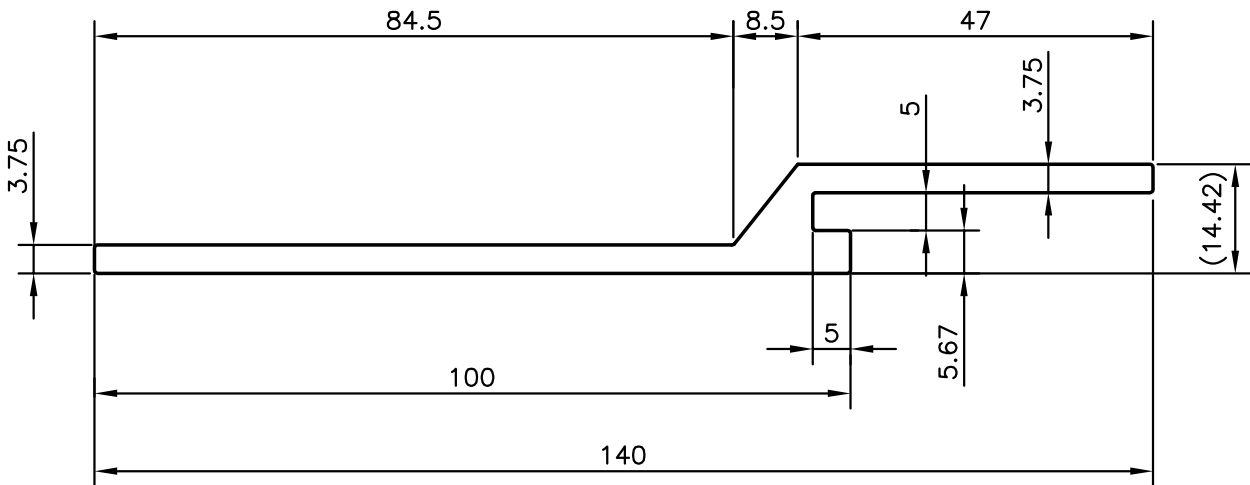

SYMBOL OF QUALITY  
AN ISO 9001 COMPANY

**JINDAL ALUMINIUM LTD.**  
BANGALORE-560073 (INDIA)

	NAME	DATE
DRAWN	J.P.KAUSHIK	12-08-2010
CHECKED		
APPROVED	S.S.GARG	17-08-2010

1. ALL DIMENSIONS ARE IN mm.
2. ROUND OFF ALL SHARP CORNERS WITH 0.40 mm.
3. TOLERANCES WILL BE AS PER IS:3965-1981 UNLESS OTHERWISE SPECIFIED

SCALE	1:1
AREA mm <sup>2</sup>	619.9
PERIMETER mm.	311.886
WEIGHT kg/m	1.674

PARTY'S NAME	GWS ENGINEERS & FABRICATORS PVT.LTD.,MUMBAI
PARTY'S DRAWING No.	GWS-CAPT-A3-DIE-DRG. NO.: -15
ALLOY & TEMPER	HE9 WP
DESCRIPTION	SUN SHED BRACKET

DRAWING No.	SECTION No.
P-10240-2	-
S2650	S2650
35775	35775