

P-11145

S3028

35791

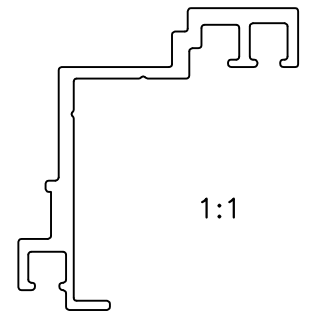

1:1

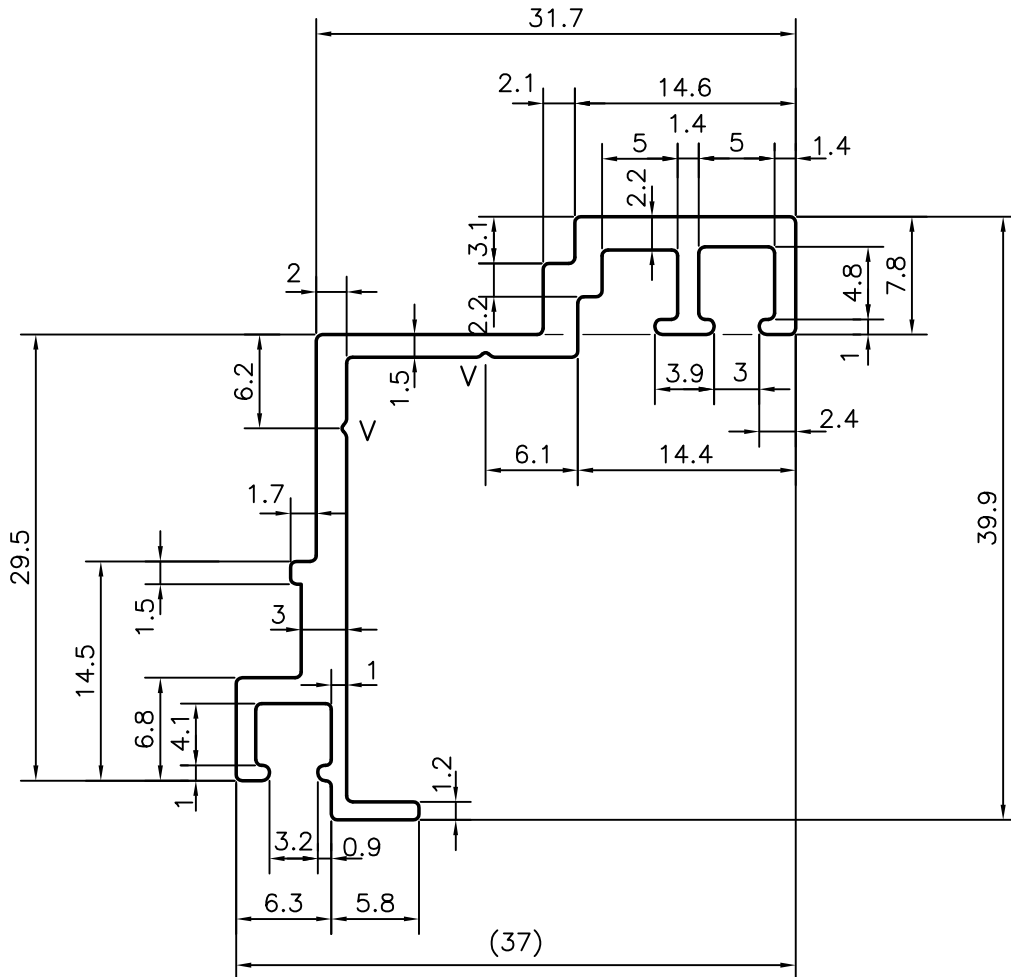

V = V GROOVE 0.3x90° (2 PLACES)



SYMBOL OF QUALITY
AN ISO 9001 COMPANY

JINDAL ALUMINIUM LTD.
BANGALORE-560073 (INDIA)

	NAME	DATE
DRAWN	J.P.KAUSHIK	02-08-2011
CHECKED		
APPROVED	S.S.GARG	11-08-2011
SCALE		2:1
AREA mm ²		177.047
PERIMETER mm.		201.18
WEIGHT kg/m		0.478
DRAWING No.	SECTION No.	
P-11145	-	
S3028	S3028	
35791	35791	

1. ALL DIMENSIONS ARE IN mm.
2. ROUND OFF ALL SHARP CORNERS WITH 0.40 mm.
3. TOLERANCES WILL BE AS PER, BS:EN-755-9 UNLESS OTHERWISE SPECIFIED

PARTY'S NAME	M.S. FACADES PVT. LTD., MUMBAI
PARTY'S DRAWING No.	AS PER DRAWING
ALLOY & TEMPER	HE9 WP
DESCRIPTION	ADAPTER SECTION