

P-12723

S3737

35793

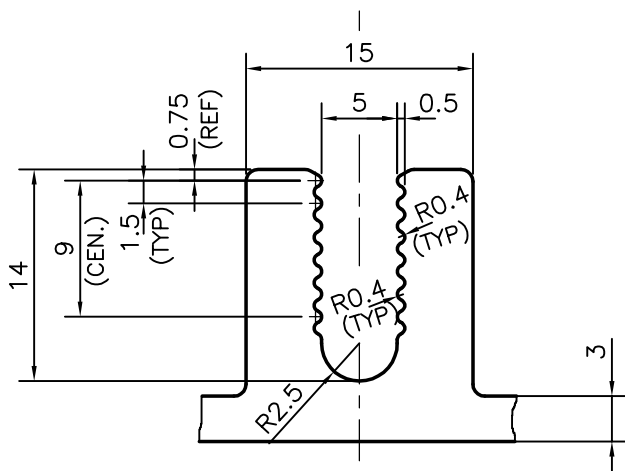

DETAILS OF "A"
SCALE 2:1

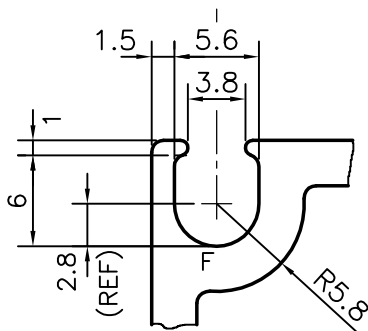

DETAILS OF "B"
SCALE 2:1

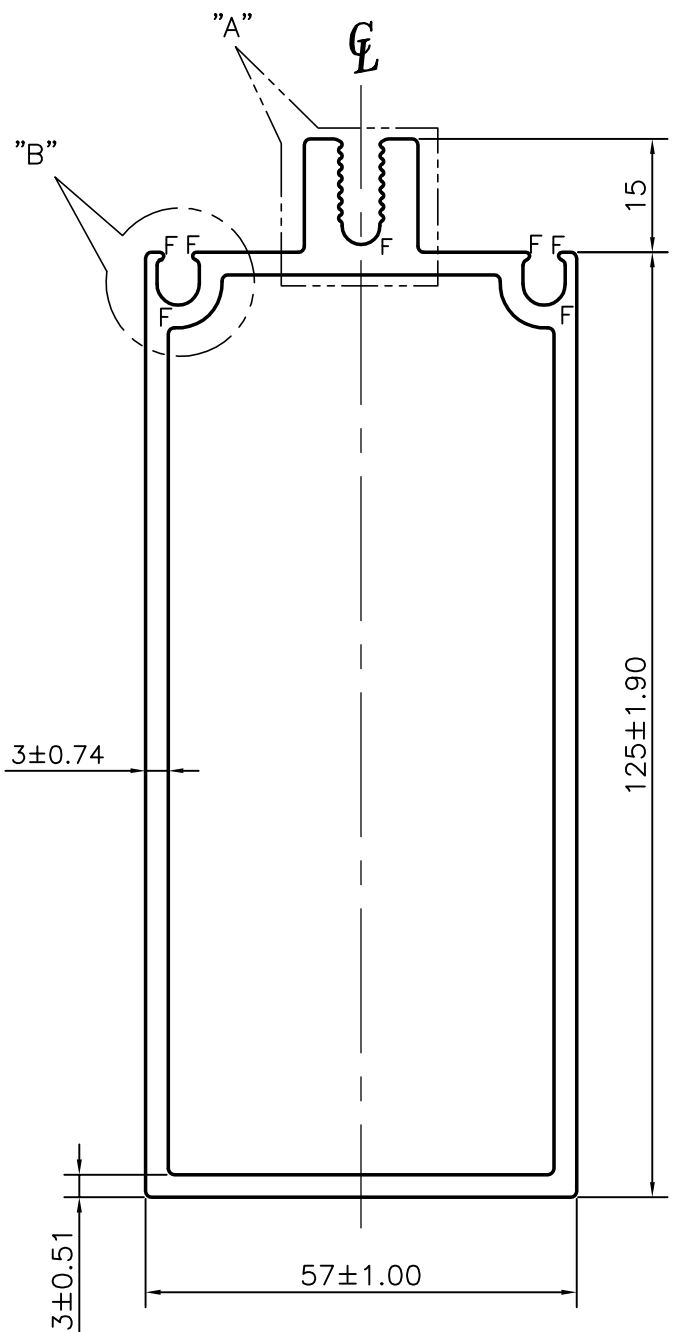

F = FULL RADIUS (7 PLACES)



SYMBOL OF QUALITY
AN ISO 9001 COMPANY

JINDAL ALUMINIUM LTD.
BANGALORE-560073 (INDIA)

	NAME	DATE
DRAWN	SRIVATHSA	08-05-2013
CHECKED		
APPROVED	S.S.GARG	10-05-2013
SCALE		1:1
AREA mm ²		1225.017
PERIMETER mm.		449.451
WEIGHT kg/m		3.308
DRAWING No.	SECTION No.	
P-12723	-	
S3737	S3737	
35793	35793	

1. ALL DIMENSIONS ARE IN mm.
2. ROUND OFF ALL SHARP CORNERS WITH 0.80 mm.
3. TOLERANCES WILL BE AS PER IS:6477-1983, UNLESS OTHERWISE SPECIFIED

PARTY'S NAME	ALLGLAZE ENTERPRISES, HYDERABAD
PARTY'S DRAWING No.	AS PER DRAWING
ALLOY & TEMPER	6063 T6
DESCRIPTION	CURTAIN WALL SECTION