

P-13792

35802

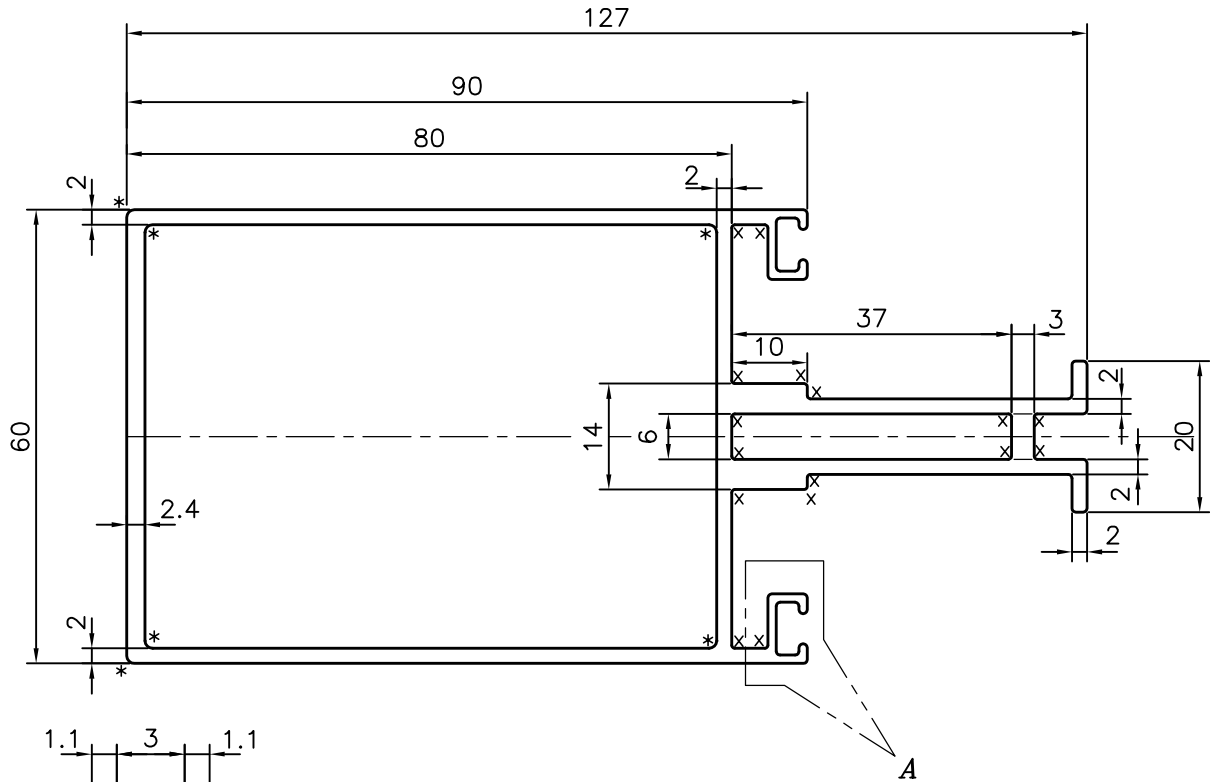

DETAIL OF "A"
SCALE 3:1

x = 0.4 RADIUS (16 PLACES)

* = 1.0 RADIUS (6 PLACES)



SYMBOL OF QUALITY
AN ISO 9001 COMPANY

JINDAL ALUMINIUM LTD.
BANGALORE-560073 (INDIA)

	NAME	DATE
DRAWN	J.P.KAUSHIK	29-07-2014
CHECKED		
APPROVED	S.S.GARG	04-08-2014
SCALE		1:1
AREA mm ²		896.785
PERIMETER mm.		495.843
WEIGHT kg/m		2.421
DRAWING No.	SECTION No.	
P-13792	-	
35802	35802	

1. ALL DIMENSIONS ARE IN mm.
2. ROUND OFF ALL SHARP CORNERS WITH 0.5 mm.
3. TOLERANCES WILL BE AS PER IS:6477-1983, UNLESS OTHERWISE SPECIFIED

PARTY'S NAME	GENERAL CATEGORY, MUMBAI MARKET
PARTY'S DRAWING No.	SAG-1061 & AS PER Auto CAD DRAWING
ALLOY & TEMPER	HE9 WP
DESCRIPTION	CURTAIN WALL SECTION