

P-11791-1

S3353

35806

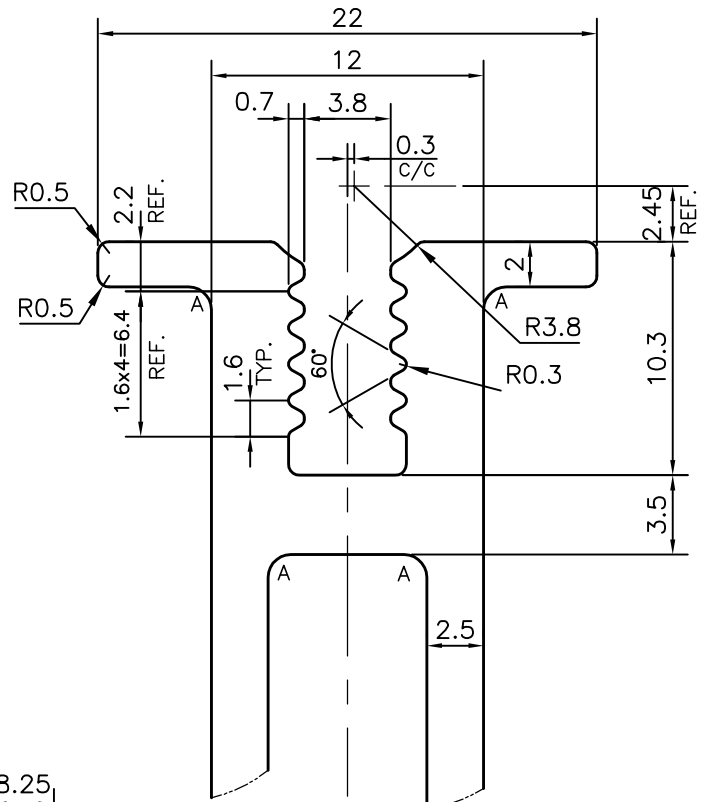
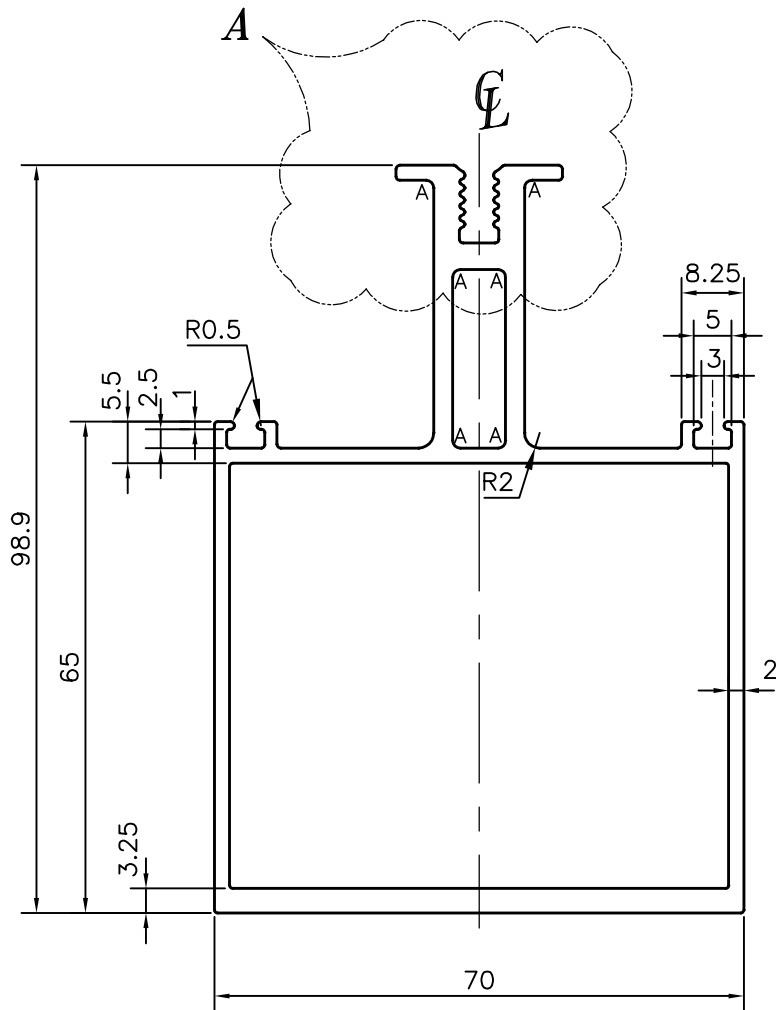

DETAIL OF "A"
SCALE 3:1

A = RADIUS 1 mm. (6 PLACES)



SYMBOL OF QUALITY
AN ISO 9001 COMPANY

JINDAL ALUMINIUM LTD.
BANGALORE-560073 (INDIA)

	NAME	DATE
DRAWN	PARVESH	08-06-2012
CHECKED		
APPROVED	S.S.GARG	18-06-2012
SCALE		1:1
AREA mm ²		877.934
PERIMETER mm.		412.234
WEIGHT kg/m		2.37
DRAWING No.	SECTION No.	
P-11791-1	-	
S3353	S3353	
35806	35806	

1. ALL DIMENSIONS ARE IN mm. 2. ROUND OFF ALL SHARP CORNERS WITH 0.40 mm. 3. TOLERANCES WILL BE AS PER IS:6477-1983, UNLESS OTHERWISE SPECIFIED	
PARTY'S NAME	HATIM GLAZING & CLADDING PVT. LTD., MUMBAI
PARTY'S DRAWING No.	ALU. TRANSOM SECTION
ALLOY & TEMPER	HE9 WP
DESCRIPTION	CURTAIN WALL SECTION