

P-11793-1

S3355

35808

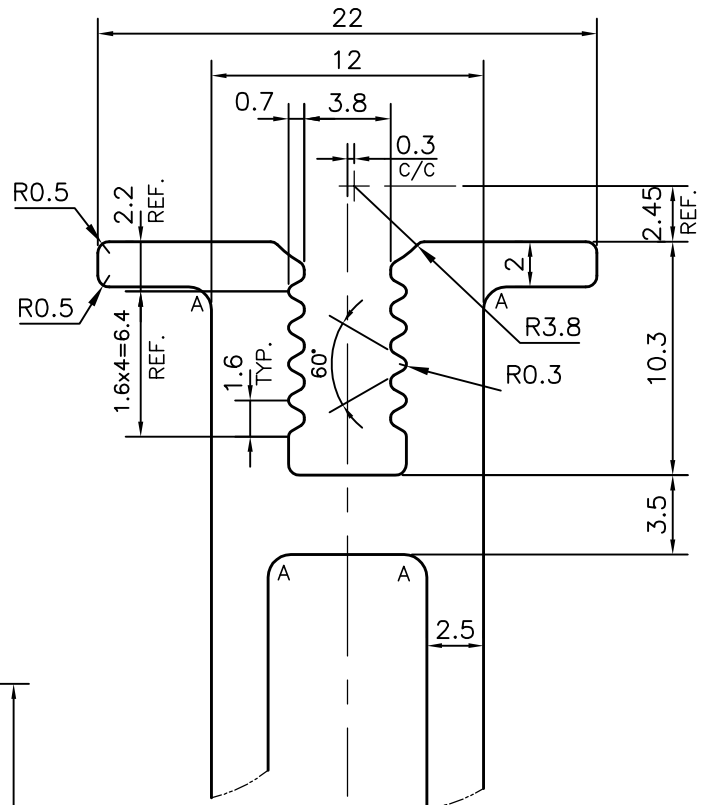
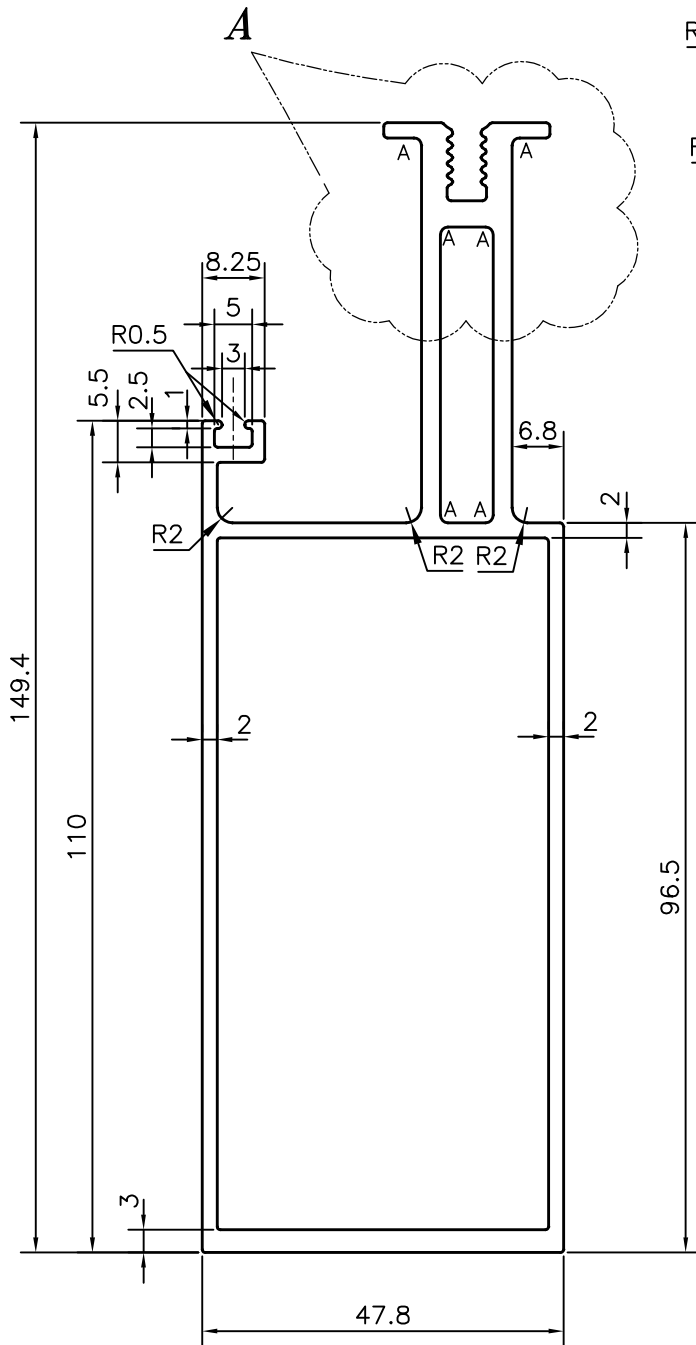

DETAIL OF "A"
SCALE 3:1

A = RADIUS 1 mm. (6 PLACES)



SYMBOL OF QUALITY
AN ISO 9001 COMPANY

JINDAL ALUMINIUM LTD.
BANGALORE-560073 (INDIA)

	NAME	DATE
DRAWN	PARVESH	08-06-2012
CHECKED		
APPROVED	S.S.GARG	18-06-2012
SCALE		1:1
AREA	mm ²	987.883
PERIMETER	mm.	484.149
WEIGHT	kg/m	2.667
DRAWING No.	SECTION No.	
P-11793-1	-	
S3355	S3355	
35808	35808	

1. ALL DIMENSIONS ARE IN mm. 2. ROUND OFF ALL SHARP CORNERS WITH 0.40 mm. 3. TOLERANCES WILL BE AS PER IS:6477-1983, UNLESS OTHERWISE SPECIFIED	
PARTY'S NAME	HATIM GLAZING & CLADDING PVT. LTD., MUMBAI
PARTY'S DRAWING No.	ALU. HALF MULLION SECTION
ALLOY & TEMPER	HE9 WP
DESCRIPTION	CURTAIN WALL SECTION