

P-11676

S3293

35814

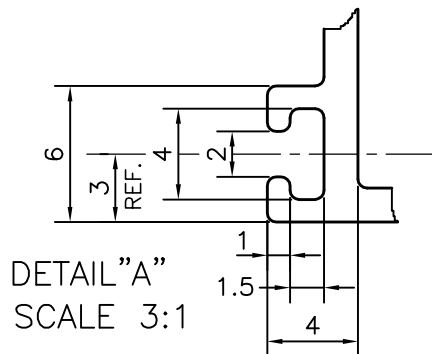
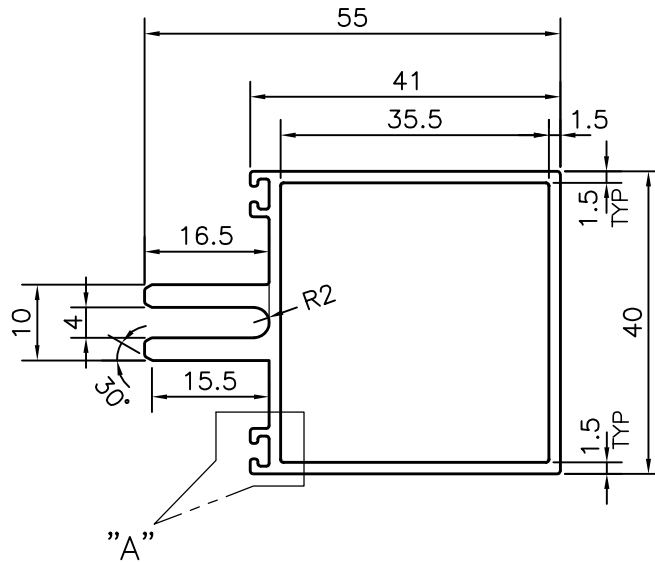

DETAIL "A"
SCALE 3:1

Q No:-71877



SYMBOL OF QUALITY
AN ISO 9001 COMPANY

JINDAL ALUMINIUM LTD.
BANGALORE-560073 (INDIA)

	NAME	DATE
DRAWN	J.P.KAUSHIK	21-04-2012
CHECKED		
APPROVED	J.N.RAI	02-06-2012
SCALE		1:1
AREA mm ²		340.088
PERIMETER mm.		243.14
WEIGHT kg/m		0.918
DRAWING No.	SECTION No.	
P-11676	-	
S3293	S3293	
35814	35814	

1. ALL DIMENSIONS ARE IN mm.
2. ROUND OFF ALL SHARP CORNERS WITH 0.40 mm.
3. TOLERANCES WILL BE AS PER,IS:6477-1983 UNLESS OTHERWISE SPECIFIED

PARTY'S NAME	SAHARA PRIME CITY LTD., GURGAON
PARTY'S DRAWING No.	TRANSOME
ALLOY & TEMPER	HE9 WP
DESCRIPTION	CURTAIN WALL SECTION