

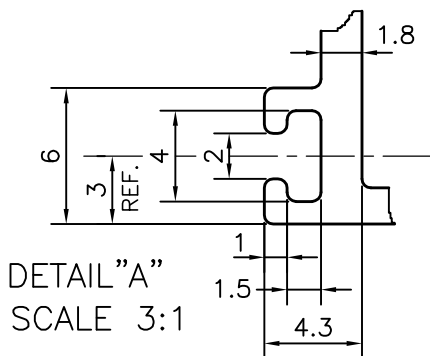

P-11677
S3294
35815

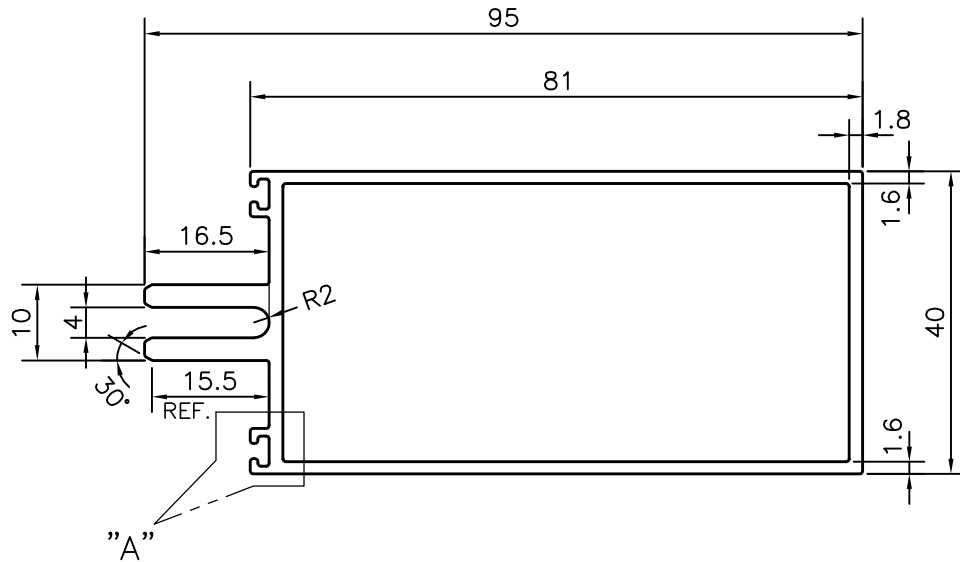

Q No:-71876

 SYMBOL OF QUALITY AN ISO 9001 COMPANY	JINDAL ALUMINIUM LTD. BANGALORE-560073 (INDIA)		NAME	DATE
		DRAWN	J.P.KAUSHIK	21-04-2012
		CHECKED		
		APPROVED	J.N.RAI	02-06-2012
1. ALL DIMENSIONS ARE IN mm. 2. ROUND OFF ALL SHARP CORNERS WITH 0.40 mm. 3. TOLERANCES WILL BE AS PER,IS:6477-1983 UNLESS OTHERWISE SPECIFIED		SCALE		1:1
		AREA mm ²		497.352
		PERIMETER mm.		322.968
		WEIGHT kg/m		1.343
PARTY'S NAME	SAHARA PRIME CITY LTD., GURGAON	DRAWING No.	SECTION No.	
PARTY'S DRAWING No.	MULLION	P-11677	-	
ALLOY & TEMPER	HE9 WP	S3294	S3294	
		35815	35815	
DESCRIPTION	CURTAIN WALL SECTION			