

P-12104

S3497

35819

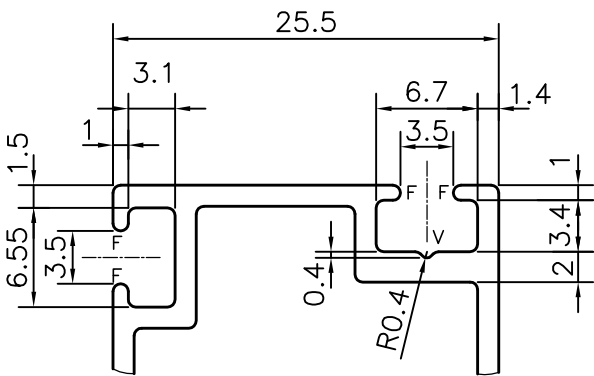
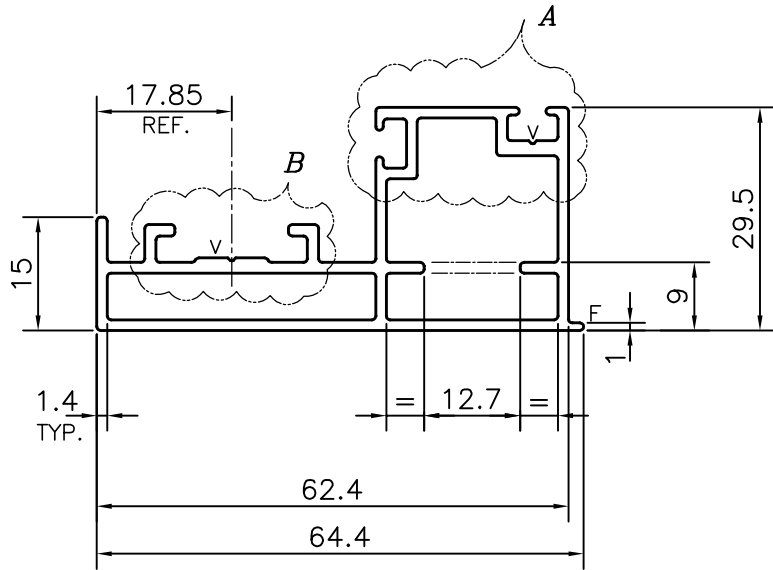

DETAIL OF "A"
SCALE :- 2:1

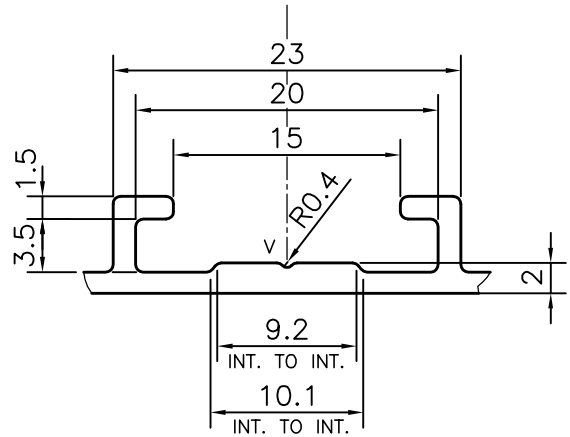

DETAIL OF "B"
SCALE :- 2:1

V = VEE GROOVE 0.4x90° (2 PLACES)
F = FULL RADIUS (5 PLACES)



SYMBOL OF QUALITY
AN ISO 9001 COMPANY

JINDAL ALUMINIUM LTD.
BANGALORE-560073 (INDIA)

	NAME	DATE
DRAWN	PARVESH	03-10-2012
CHECKED		
APPROVED	S.S.GARG	10-10-2012
SCALE		1:1
AREA mm ²		333.996
PERIMETER mm.		252.026
WEIGHT kg/m		0.902
DRAWING No.	SECTION No.	
P-12104	-	
S3497	S3497	
35819	35819	

1. ALL DIMENSIONS ARE IN mm.
2. ROUND OFF ALL SHARP CORNERS WITH 0.50 mm.
3. TOLERANCES WILL BE AS PER IS:6477-1983, UNLESS OTHERWISE SPECIFIED

PARTY'S NAME	DESAI INFRASTRUCTURE PVT. LTD., NAVSARI
PARTY'S DRAWING No.	FITI/DIE-03
ALLOY & TEMPER	HE9 WP
DESCRIPTION	CURTAIN WALL SECTION- SUBFRAME-1