

P-12105

S3498

35820

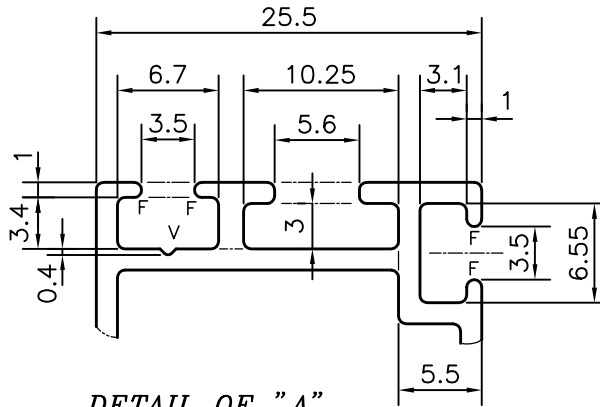
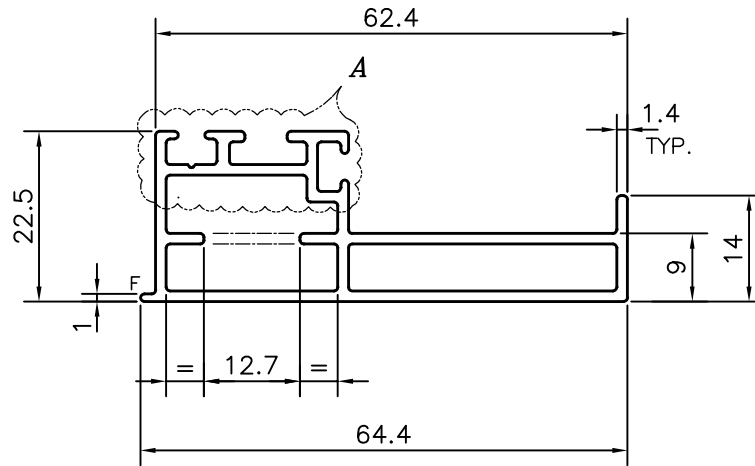

DETAIL OF "A"
SCALE :- 2:1

V = VEE GROOVE 0.5x90° (1 PLACES)
F = FULL RADIUS (5 PLACES)



SYMBOL OF QUALITY
AN ISO 9001 COMPANY

JINDAL ALUMINIUM LTD.
BANGALORE-560073 (INDIA)

	NAME	DATE
DRAWN	PARVESH	03-10-2012
CHECKED		
APPROVED	S.S.GARG	10-10-2012
SCALE		1:1
AREA	mm ²	287.249
PERIMETER	mm.	224.374
WEIGHT	kg/m	0.776
DRAWING No.	SECTION No.	
P-12105	-	
S3498	S3498	
35820	35820	

1. ALL DIMENSIONS ARE IN mm.
2. ROUND OFF ALL SHARP CORNERS WITH 0.50 mm.
3. TOLERANCES WILL BE AS PER IS:6477-1983, UNLESS OTHERWISE SPECIFIED

PARTY'S NAME	DESAI INFRASTRUCTURE PVT. LTD., NAVSARI
PARTY'S DRAWING No.	FITI/DIE-04
ALLOY & TEMPER	HE9 WP
DESCRIPTION	CURTAIN WALL SECTION- SUBFRAME-2