

P-12087

S3484

35842

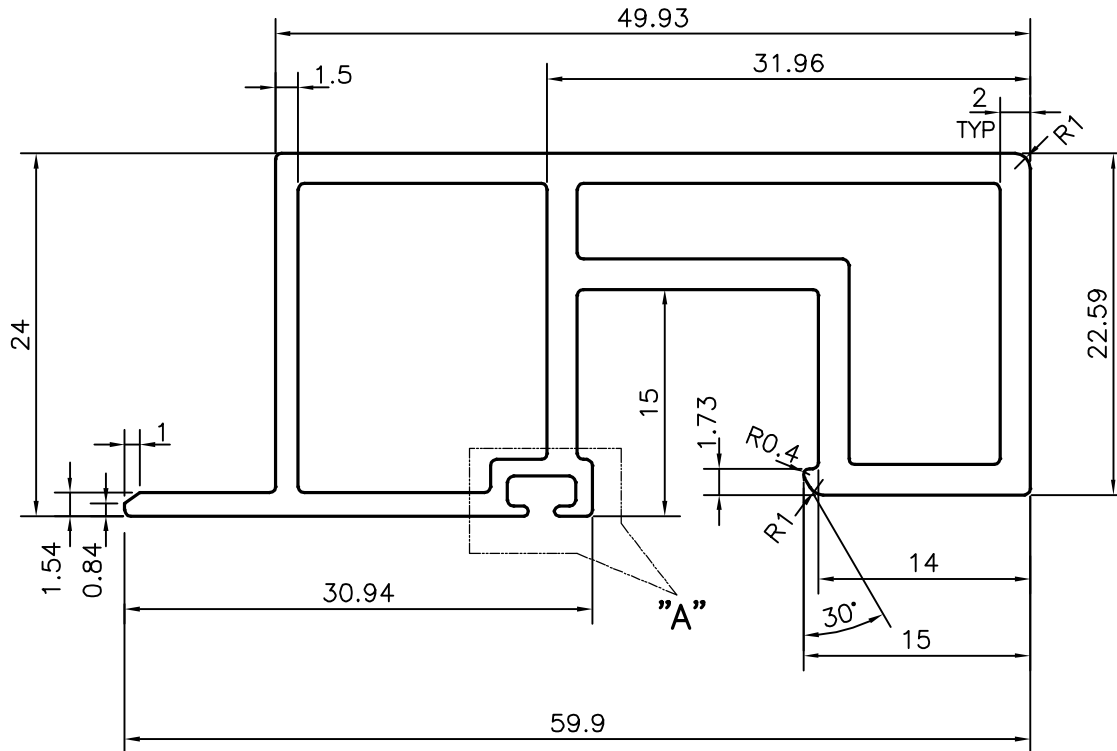
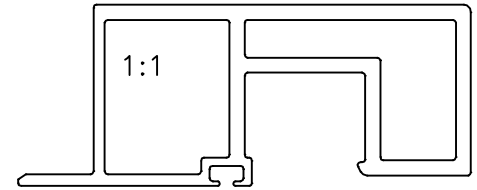
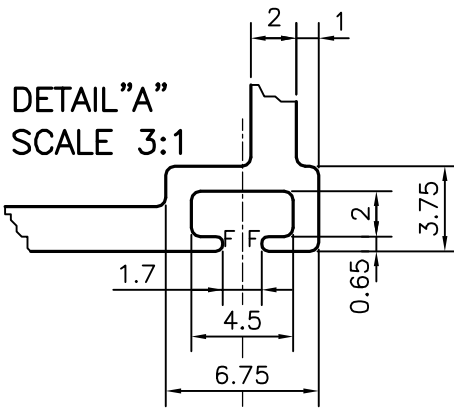

Q74824

F = FULL RADIUS (2 PLACES)



SYMBOL OF QUALITY
AN ISO 9001 COMPANY

JINDAL ALUMINIUM LTD.
BANGALORE-560073 (INDIA)

	NAME	DATE
DRAWN	J.P.KAUSHIK	28-09-2012
CHECKED		
APPROVED	S.S.GARG	05-10-2012
SCALE		2:1
AREA mm ²		344.756
PERIMETER mm.		205.209
WEIGHT kg/m		0.931
DRAWING No.	SECTION No.	
P-12087	-	
S3484	S3484	
35842	35842	

1. ALL DIMENSIONS ARE IN mm.
2. ROUND OFF ALL SHARP CORNERS WITH 0.40 mm.
3. TOLERANCES WILL BE AS PER IS:6477-1983 UNLESS OTHERWISE SPECIFIED

PARTY'S NAME	SOBHA DEVELOPERS LTD.,BANGALORE
PARTY'S DRAWING No.	AS PER DRAWING
ALLOY & TEMPER	6063 T5
DESCRIPTION	GLASS FRAME SECTION