

P-12088
S3485
35843

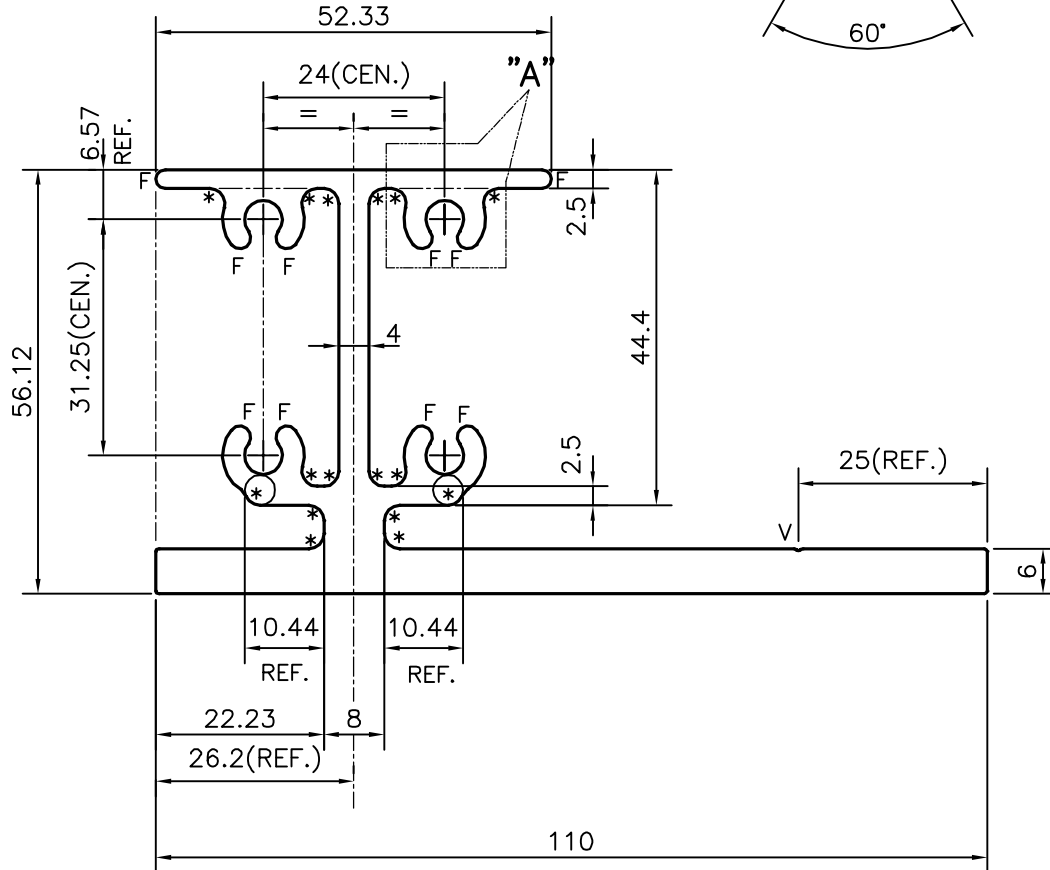
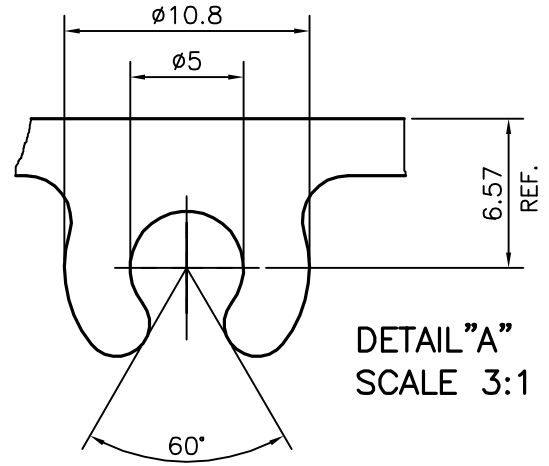

V = V GROOVE 0.3x90°

F = FULL RADIUS ( 10 PLACES )

\* = 2.0 RADIUS ( 16 PLACES )

Q74823

 SYMBOL OF QUALITY AN ISO 9001 COMPANY	<b>JINDAL ALUMINIUM LTD.</b> BANGALORE-560073 (INDIA)	NAME		DATE	
		DRAWN	J.P.KAUSHIK	28-09-2012	
1. ALL DIMENSIONS ARE IN mm. 2. ROUND OFF ALL SHARP CORNERS WITH 0.40 mm. 3. TOLERANCES WILL BE AS PER IS:3965-1981 UNLESS OTHERWISE SPECIFIED		CHECKED			
		APPROVED	S.S.GARG	05-10-2012	
PARTY'S NAME		SOBHA DEVELOPERS LTD.,BANGALORE		SCALE	1:1
		PARTY'S DRAWING No.		AS PER DRAWING	AREA mm <sup>2</sup>
ALLOY & TEMPER		6063 T5		PERIMETER mm.	564.419
		DESCRIPTION		MULLION BOTTOM BRACKET	WEIGHT kg/m
		DRAWING No.		SECTION No.	
		P-12088		-	
		S3485		S3485	
		35843		35843	