

P-12166

S3548

35850

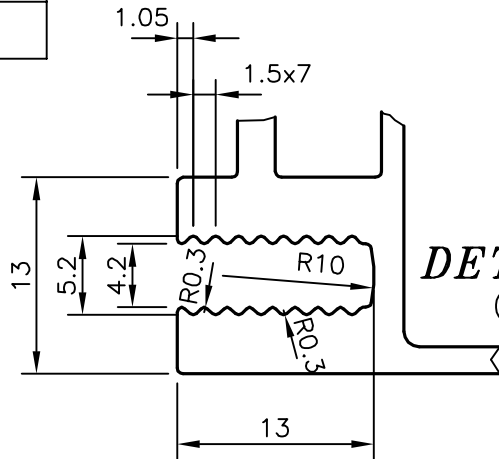

DETAIL 'B'
(2:1)

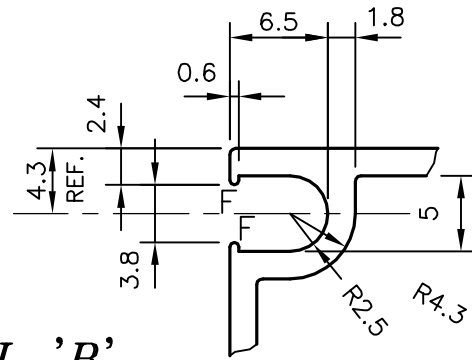

DETAIL 'A'
(2:1)

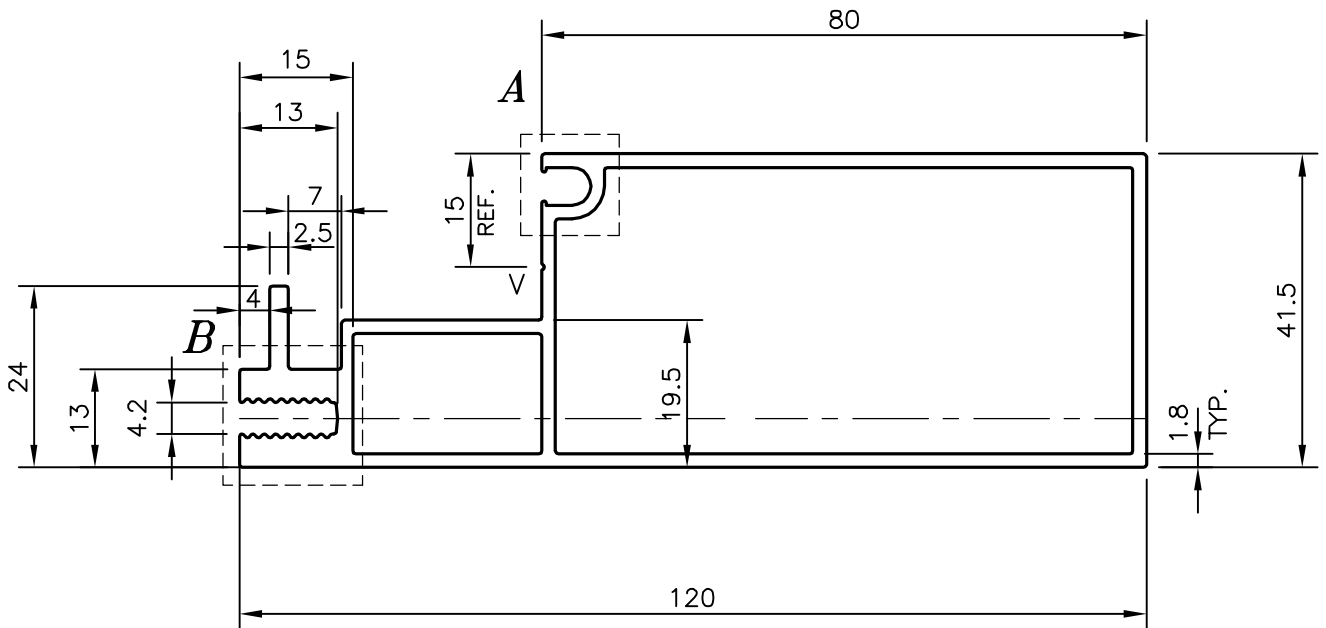

V = V GROOVE 0.3x90°
F= FULL RADIUS (2 PLACES)



SYMBOL OF QUALITY
AN ISO 9002 COMPANY

JINDAL ALUMINIUM LTD.
BANGALORE-560073 (INDIA)

	NAME	DATE
DRAWN	J.P.KAUSHIK	20-10-2012
CHECKED		
APPROVED	S.S.GARG	06-11-2012
SCALE		1:1
AREA mm ²		697.474
PERIMETER mm.		386.803
WEIGHT kg/m		1.883
DRAWING No.	SECTION No.	
P-12166	-	
S3548	S3548	
35850	35850	

1. ALL DIMENSIONS ARE IN mm. 2. ROUND OFF ALL SHARP CORNERS WITH 0.40 mm. 3. TOLERANCES WILL BE AS PER IS:6477-1983 UNLESS OTHERWISE SPECIFIED	
PARTY'S NAME	TRIDENT ARCHITECTURAL ALUMINIUM PRODUCTS PVT.LTD., BANGALORE
PARTY'S DRAWING No.	AS PER SAMPLE
ALLOY & TEMPER	HE9 WP
DESCRIPTION	CURTAIN WALL SECTION