

P-12208

S3620

35853

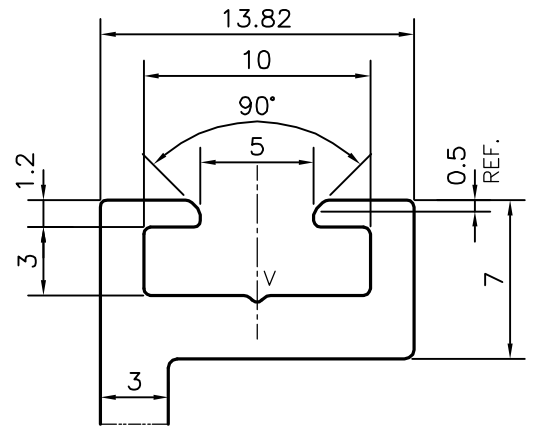
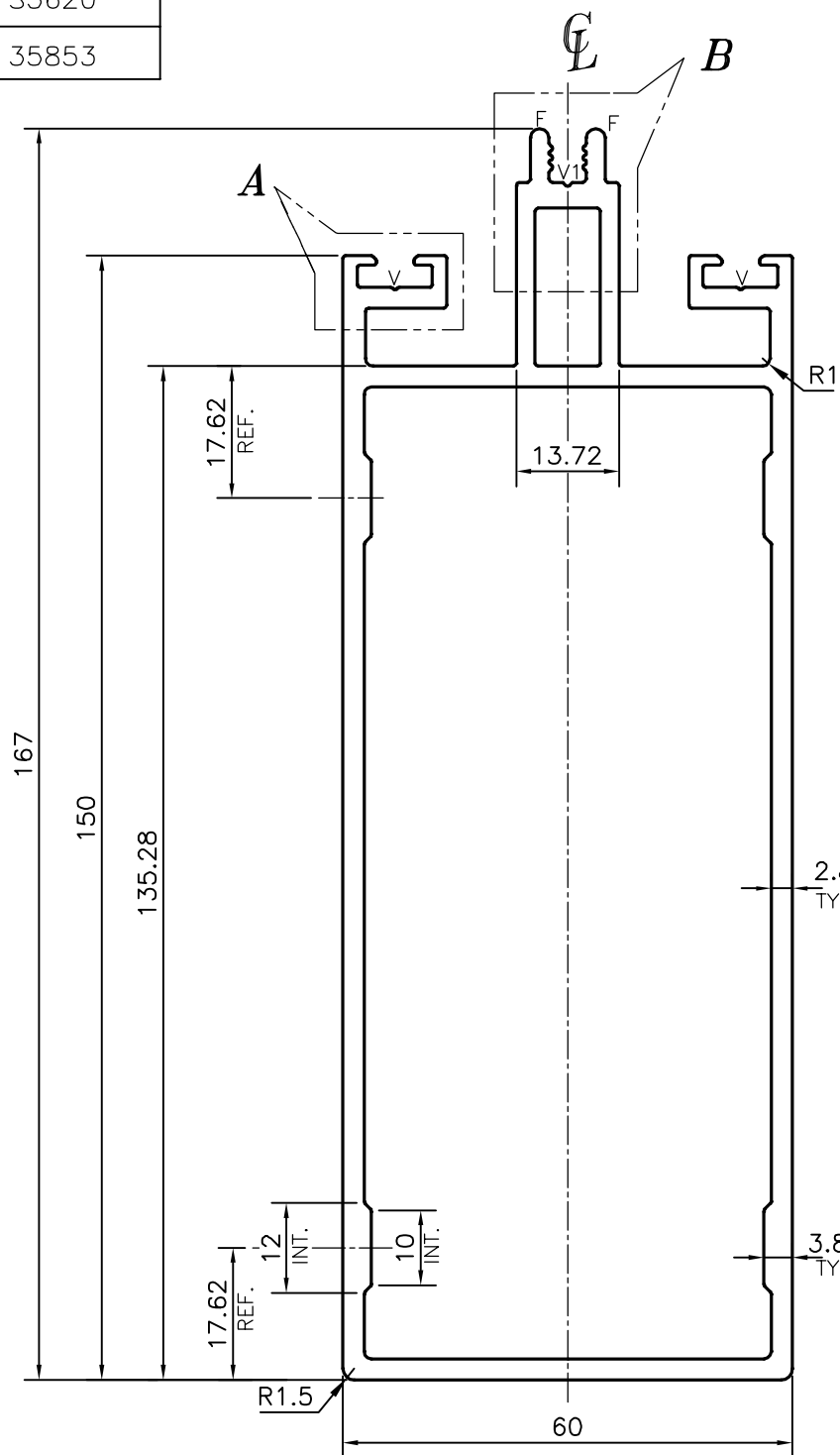

DETAIL OF "A"  
SCALE- 2:1

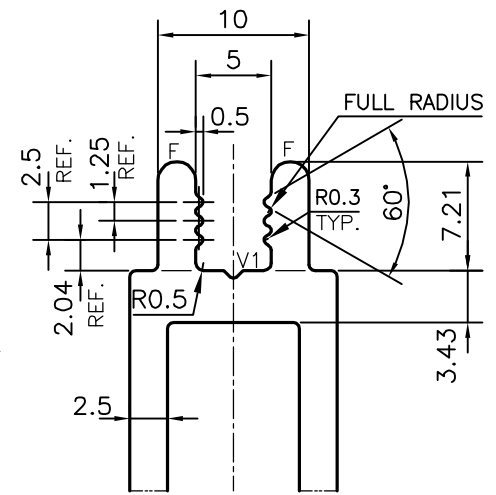

DETAIL OF "B"  
SCALE- 2:1

F = FULL RADIUS (2 PLACES)  
 V = VEE GROOVE 0.3x90° (2 PLACES)  
 V1 = VEE GROOVE 0.5x90° (1 PLACE)



SYMBOL OF QUALITY  
AN ISO 9001 COMPANY

**JINDAL ALUMINIUM LTD.**  
BANGALORE-560073 (INDIA)

	NAME	DATE
DRAWN	PARVESH	03-11-2012
CHECKED		
APPROVED	S.S.GARG	29-01-2013
SCALE		1:1
AREA	mm <sup>2</sup>	1462.494
PERIMETER	mm.	601
WEIGHT	kg/m	3.949
DRAWING No.	SECTION No.	
P-12208	-	
S3620	S3620	
35853	35853	

1. ALL DIMENSIONS ARE IN mm.
2. ROUND OFF ALL SHARP CORNERS WITH 0.40 mm.
3. TOLERANCES WILL BE AS PER IS:6477-1983 , UNLESS OTHERWISE SPECIFIED

PARTY'S NAME	SOBHA GLAZING & METAL WORKS PVT. LTD., BANGALORE
PARTY'S DRAWING No.	AS PER DRAWING
ALLOY & TEMPER	6063 T5
DESCRIPTION	CURTAIN WAL SECTION-MULLION