

P-12474

S3633

35855

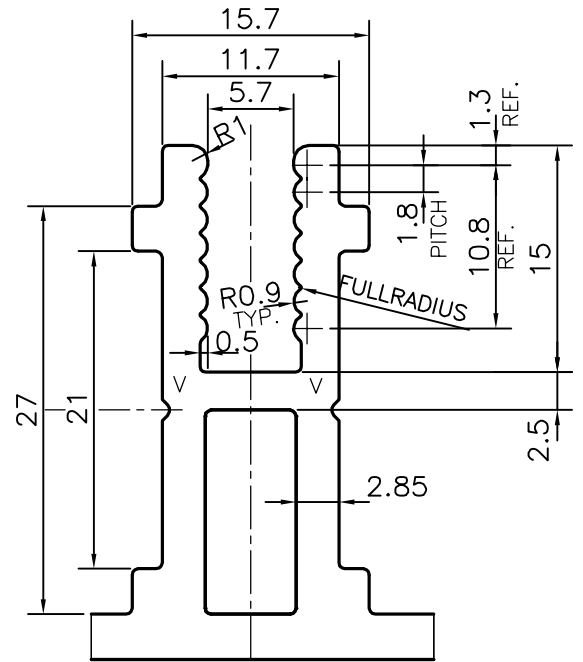
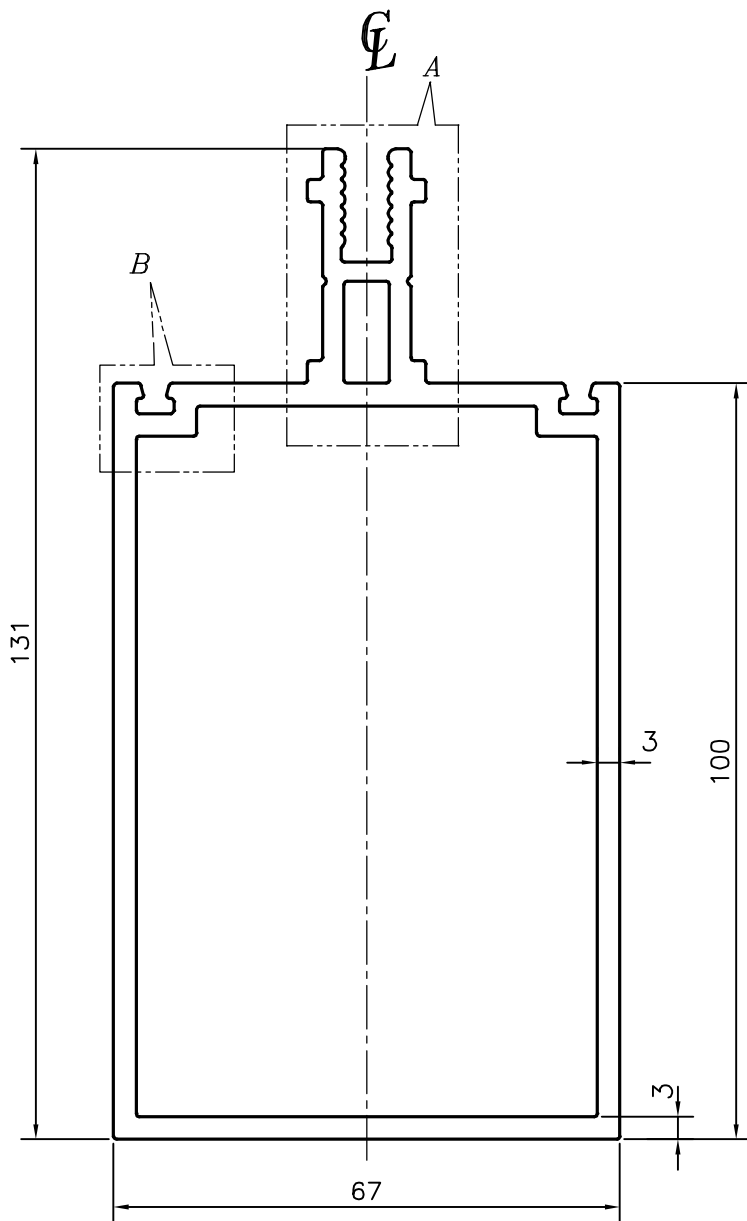

DETAIL OF 'A'
SCALE :- 2:1

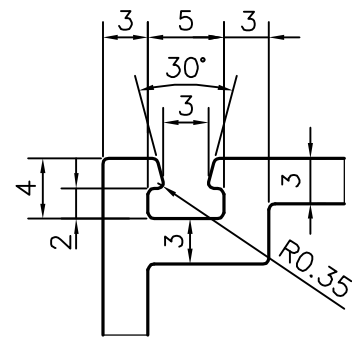

DETAIL OF 'B'
SCALE :- 2:1



SYMBOL OF QUALITY
AN ISO 9001 COMPANY

JINDAL ALUMINIUM LTD.
BANGALORE-560073 (INDIA)

	NAME	DATE
DRAWN	PARVESH	25-01-2013
CHECKED		
APPROVED	S.S.GARG	06-02-2013
SCALE		1:1
AREA mm ²		1209.647
PERIMETER mm.		455.789
WEIGHT kg/m		3.266
DRAWING No.	SECTION No.	
P-12474	-	
S3633	S3633	
35855	35855	

1. ALL DIMENSIONS ARE IN mm.
2. ROUND OFF ALL SHARP CORNERS WITH 0.40 mm.
3. TOLERANCES WILL BE AS PER IS:6477-1983 , UNLESS OTHERWISE SPECIFIED

PARTY'S NAME	UNIFAB ENERGY FACADE SOLUTION PVT. LTD., BHUBANESHWAR
PARTY'S DRAWING No.	MODIFIED OF SECTION No.- 22843
ALLOY & TEMPER	HE9 WP
DESCRIPTION	CURTAIN WALL SECTION- MULLION