

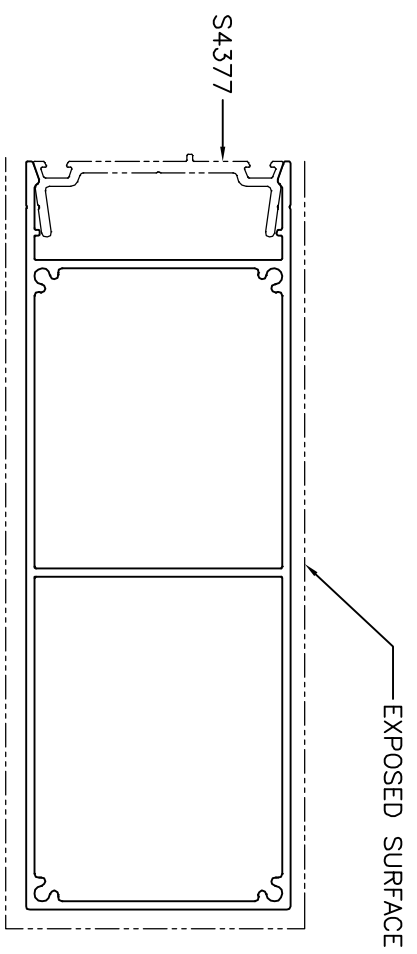

P-14397
S4376
35867

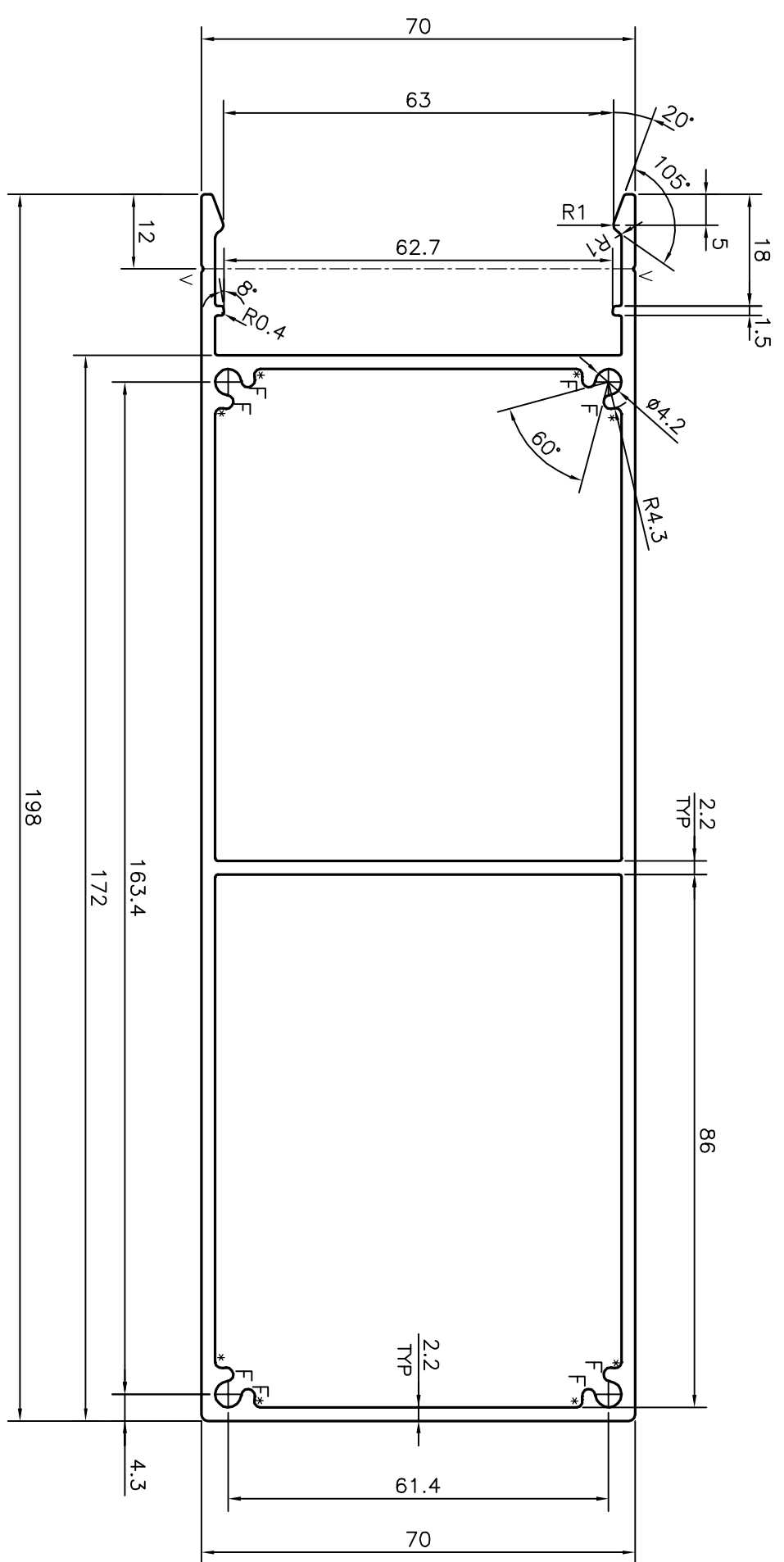

* = 1.0 RADIUS (8 PLACES)
 V = V GROOVE 0.3x90° (2 PLACES)
 F = FULL RADIUS (8 PLACES)

 SYMBOL OF QUALITY AN ISO 9001 COMPANY		JINDAL ALUMINIUM LTD. BANGALORE-560073 (INDIA)	
1. ALL DIMENSIONS ARE IN mm. 2. ROUND OFF ALL SHARP CORNERS WITH 0.40 mm. 3. TOLERANCES WILL BE AS PER IS:6477-1983 UNLESS OTHERWISE SPECIFIED			
PARTY'S NAME	A.S.FABTECH (INDIA) PVT. LTD., KOLKATA		
PARTY'S DRAWING No.	AS PER AutocAD DRAWING & REQUIREMENT		
ALLOY & TEMPER	HE9 WP		
DESCRIPTION	COVER PLATE SECTION		
DRAWN	NAME	DATE	
CHECKED	J.P.KAUSHIK	02-02-2015	
APPROVED	S.S.GARG	05-02-2015	
SCALE	1:1		
AREA	mm ²	1373.672	
PERIMETER	mm.	591.661	
WEIGHT	kg/m	3.709	
DRAWING No.	SECTION No.		
P-14397	-		
S4376	S4376		
35867	35867		