

P-14664

S4473

35878

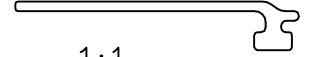

1:1

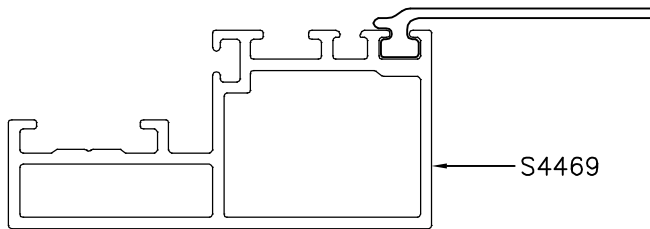
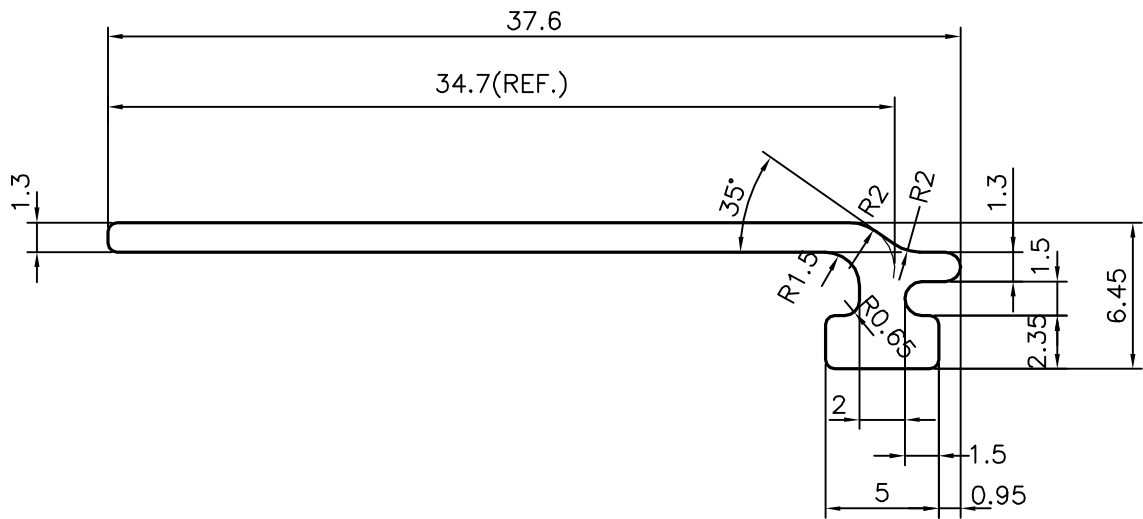

S4469



SYMBOL OF QUALITY
AN ISO 9002 COMPANY

JINDAL ALUMINIUM LTD.
BANGALORE-560073 (INDIA)

	NAME	DATE
DRAWN	J.P.KAUSHIK	21-05-2015
CHECKED		
APPROVED	S.S.GARG	25-05-2015

1. ALL DIMENSIONS ARE IN mm.
2. ROUND OFF ALL SHARP CORNERS WITH 0.40 mm.
3. TOLERANCES WILL BE AS PER IS:3965-1981 UNLESS OTHERWISE SPECIFIED

SCALE	3:1
AREA mm ²	65.499
PERIMETER mm.	89.976
WEIGHT kg/m	0.177

PARTY'S NAME	NIKITHA FACADE SYSTEMS, BANGALORE	DRAWING No.	SECTION No.
PARTY'S DRAWING No.	AS PER DRAWING NFS-DIE-8	P-14664	-
ALLOY & TEMPER	6063 T6	S4473	S4473
		35878	35878
DESCRIPTION	CURTAIN WALL SECTION-GLASS HOLDER		